



(19) **United States**

(12) **Patent Application Publication**
Chung et al.

(10) **Pub. No.: US 2007/0024542 A1**

(43) **Pub. Date: Feb. 1, 2007**

(54) **DATA DRIVING CIRCUITS AND DRIVING METHODS OF ORGANIC LIGHT EMITTING DISPLAYS USING THE SAME**

Publication Classification

(51) **Int. Cl.**
G09G 3/30 (2006.01)

(52) **U.S. Cl.** **345/76**

(76) **Inventors:** **Bo Yong Chung**, Seoul (KR); **Do Hyung Ryu**, Suwon-si (KR); **Hong Kwon Kim**, Euiwang-si (KR); **Oh Kyong Kwon**, Seoul (KR)

(57) **ABSTRACT**

A data driving circuit for driving pixels of a light emitting display to display images with uniform brightness may include a gamma voltage unit that generates a plurality of gray scale voltages, a digital-analog converter that selects, as a data signal, one of the plurality of gray scale voltages using first data, a decoder that generates second data using the first data, a current sink, a voltage controller that controls a voltage value of the data signal using the second data and a compensation voltage generated based on the predetermined current, and a switching unit that supplies the data signal to the pixel during any partial period of the complete period elapsing after the first partial period. The current sink receives a predetermined current from the pixel during a first partial period of a complete period for driving the pixel based on the selected gray scale voltage.

Correspondence Address:

LEE & MORSE, P.C.
3141 FAIRVIEW PARK DRIVE
SUITE 500
FALLS CHURCH, VA 22042 (US)

(21) **Appl. No.:** **11/491,880**

(22) **Filed:** **Jul. 25, 2006**

(30) **Foreign Application Priority Data**

Aug. 1, 2005 (KR) 2005-70438

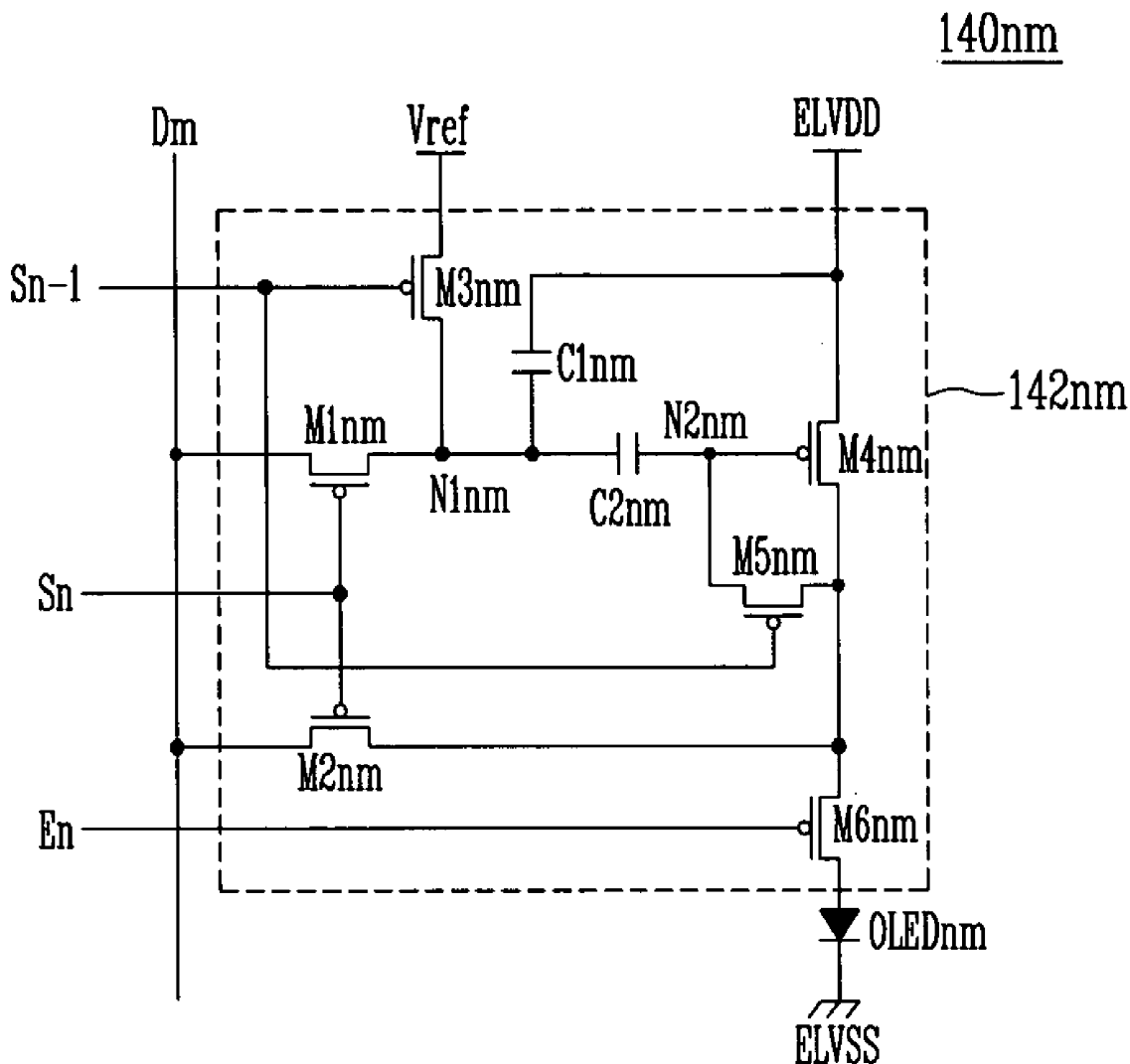

FIG. 1
(RELATED ART)

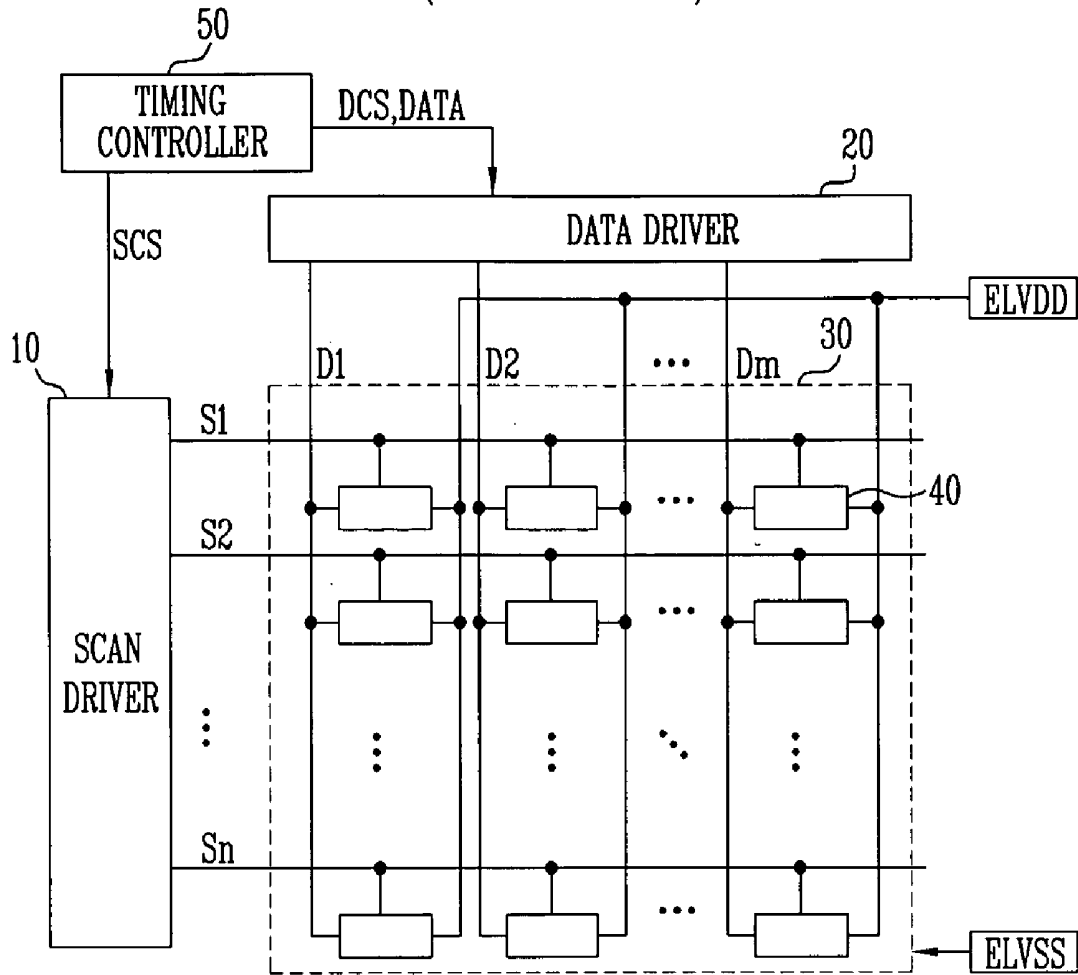

FIG. 2

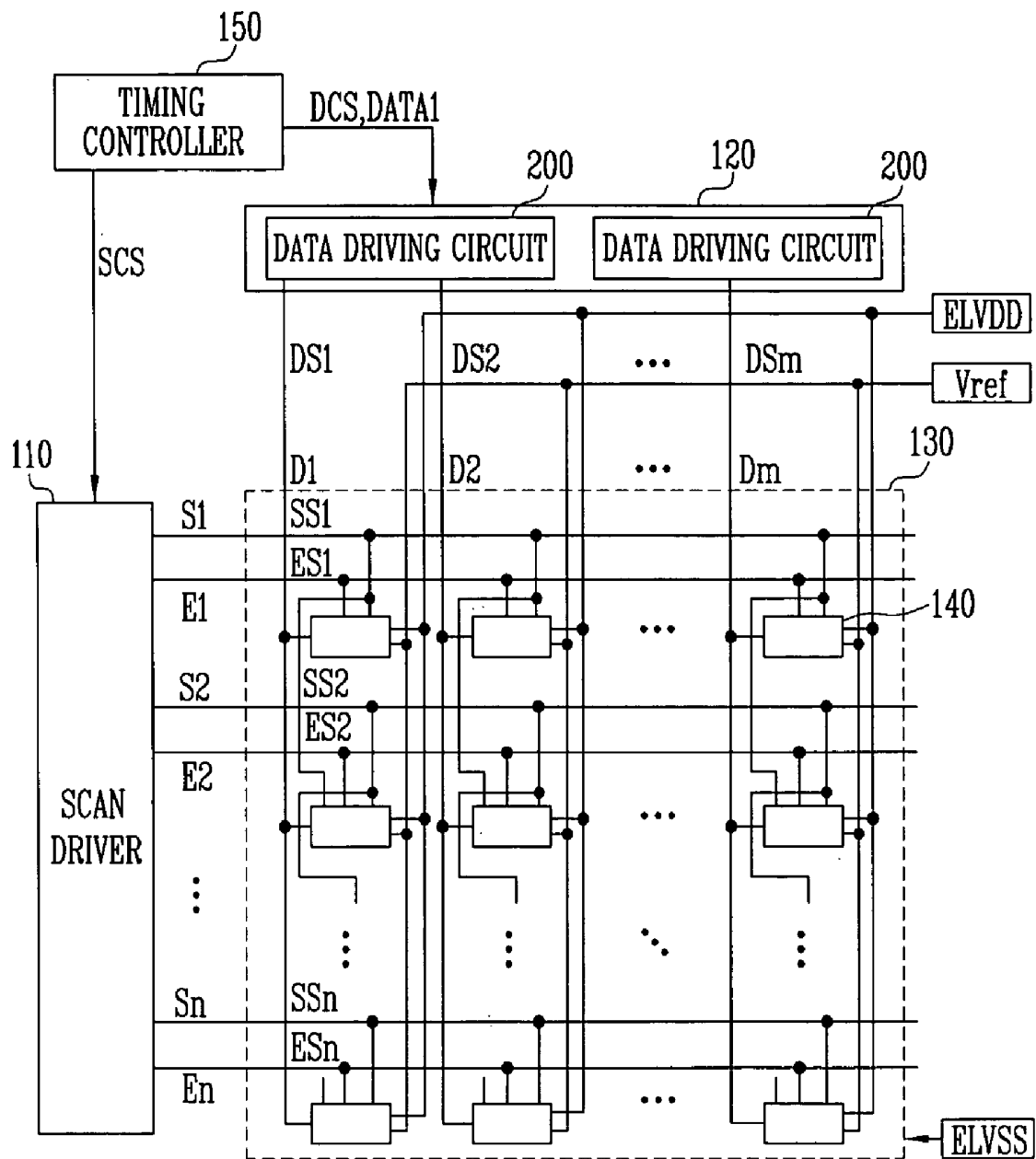

FIG. 3

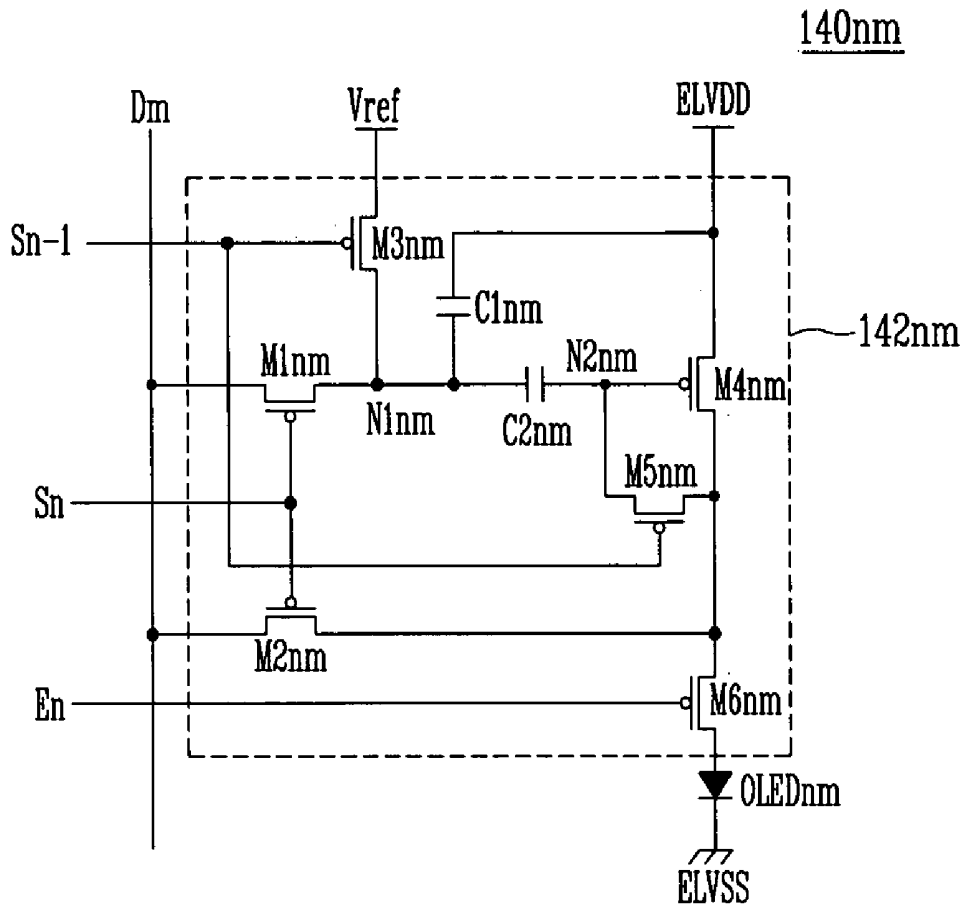

FIG. 4

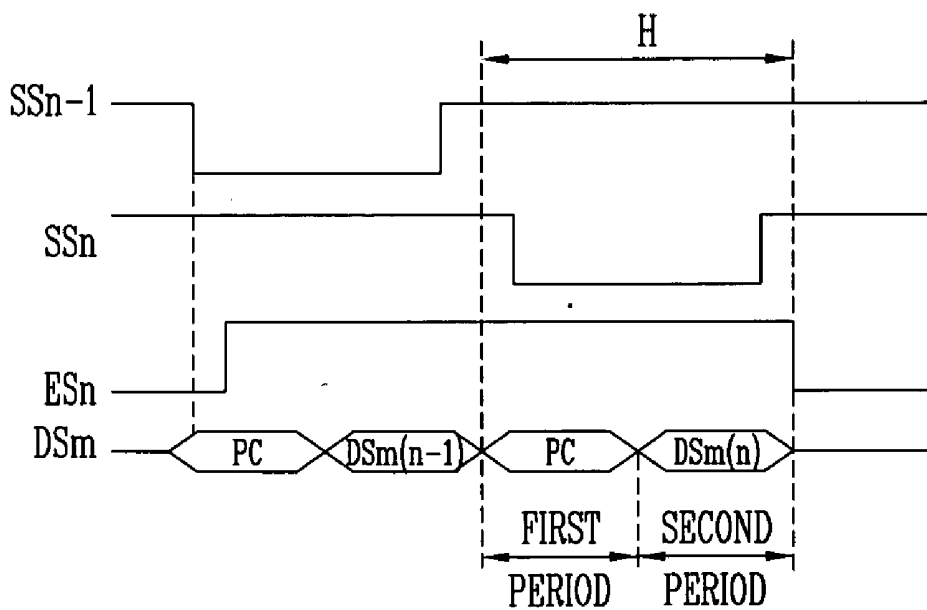

FIG. 5

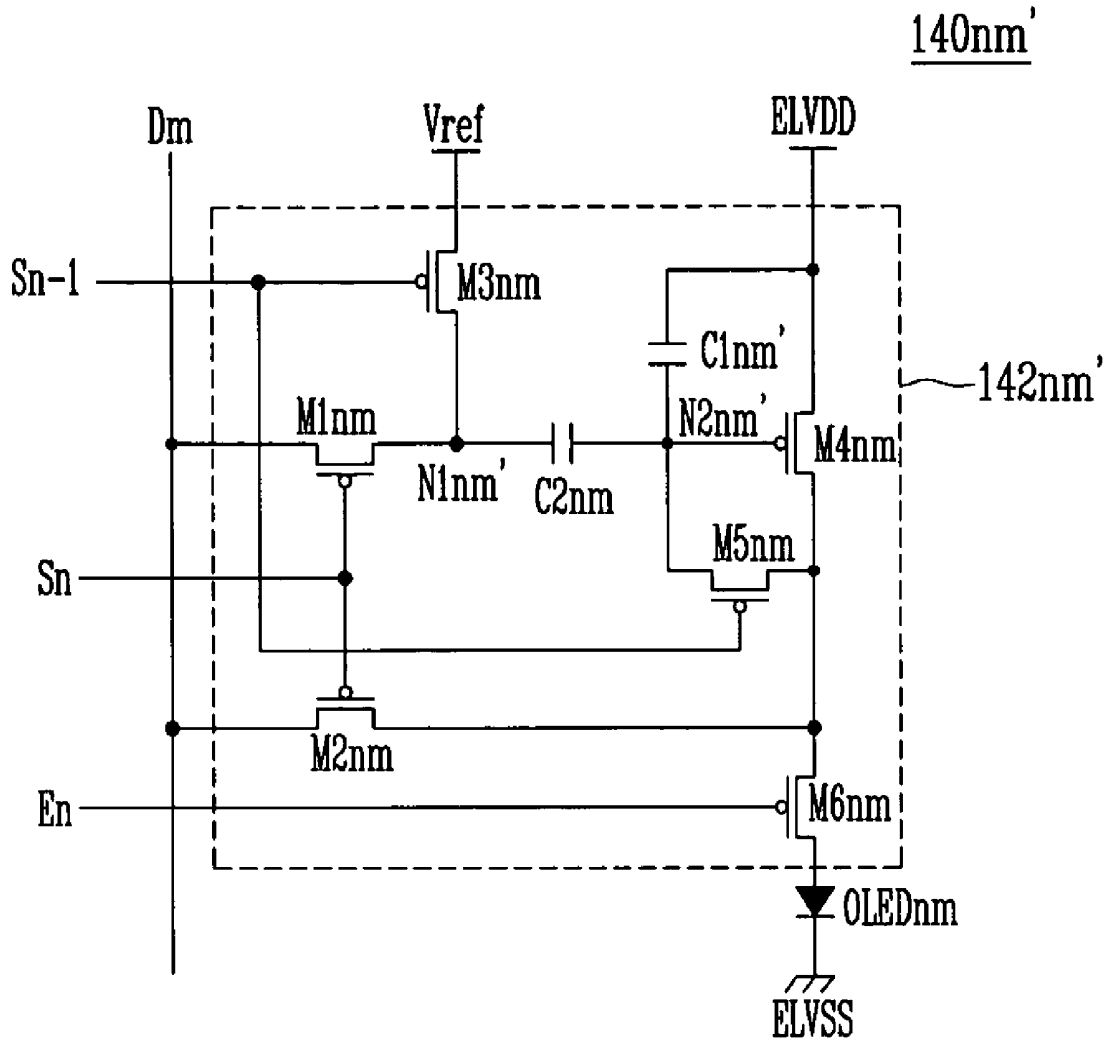

FIG. 6

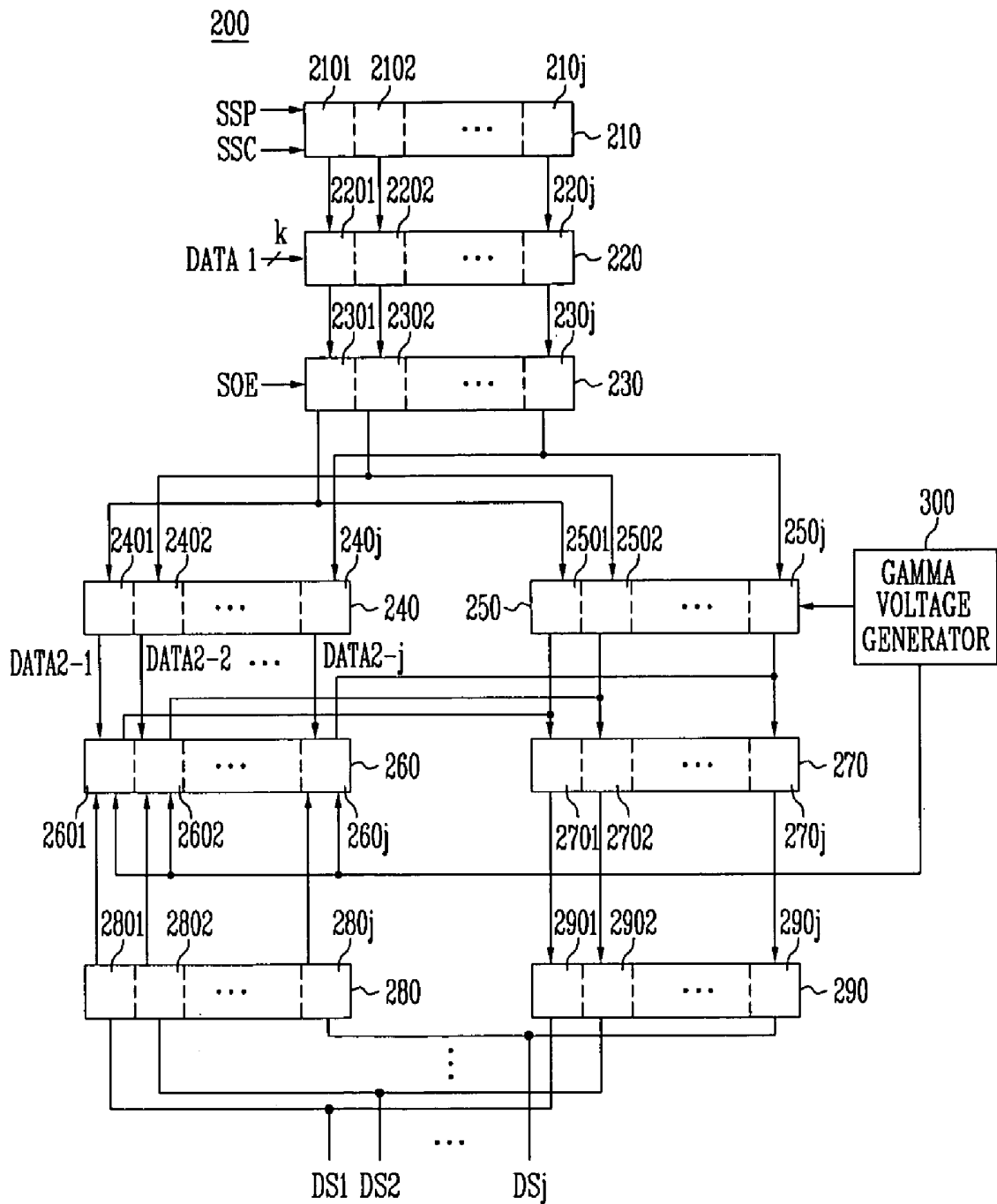

FIG. 7

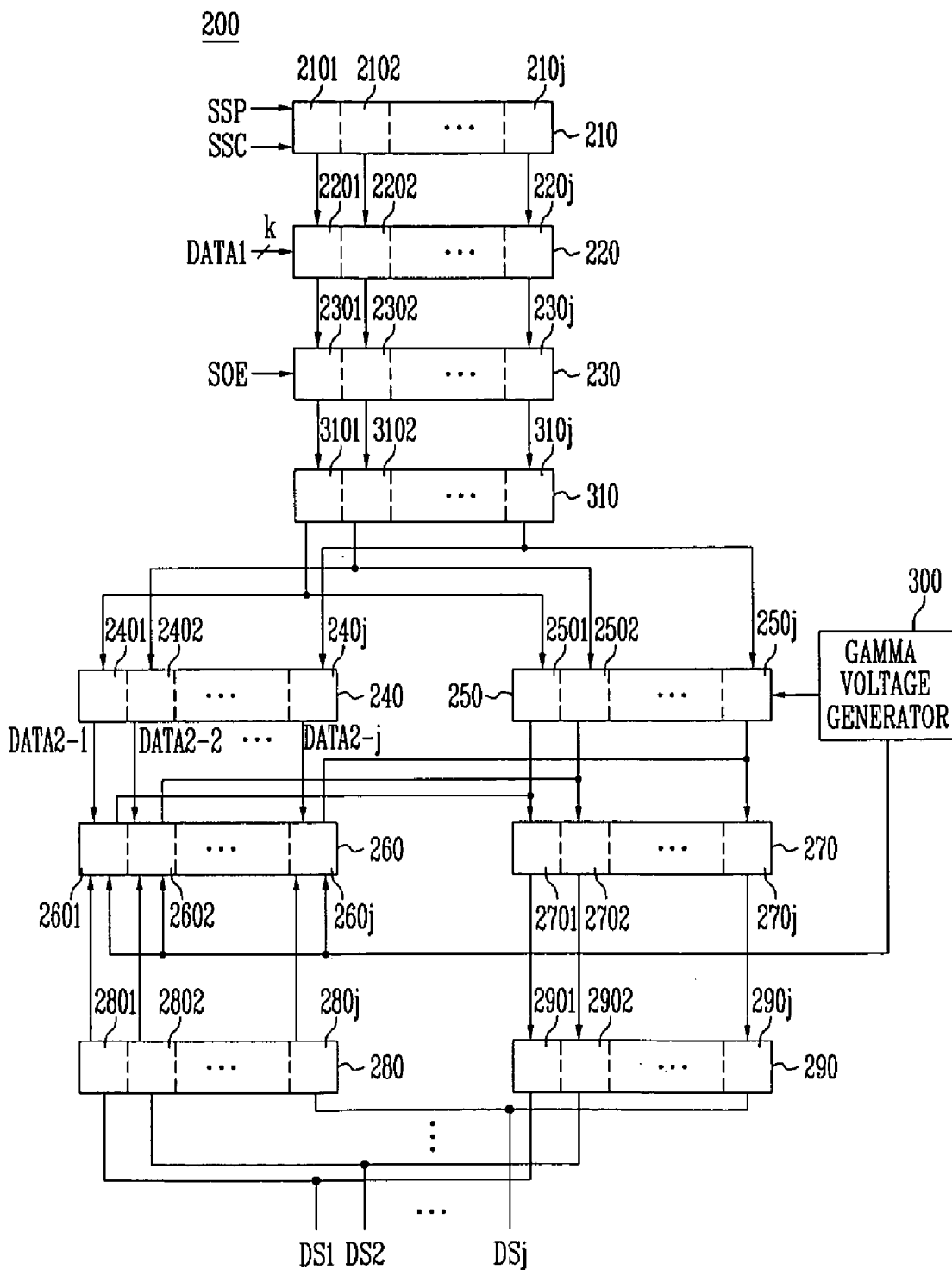

FIG. 8

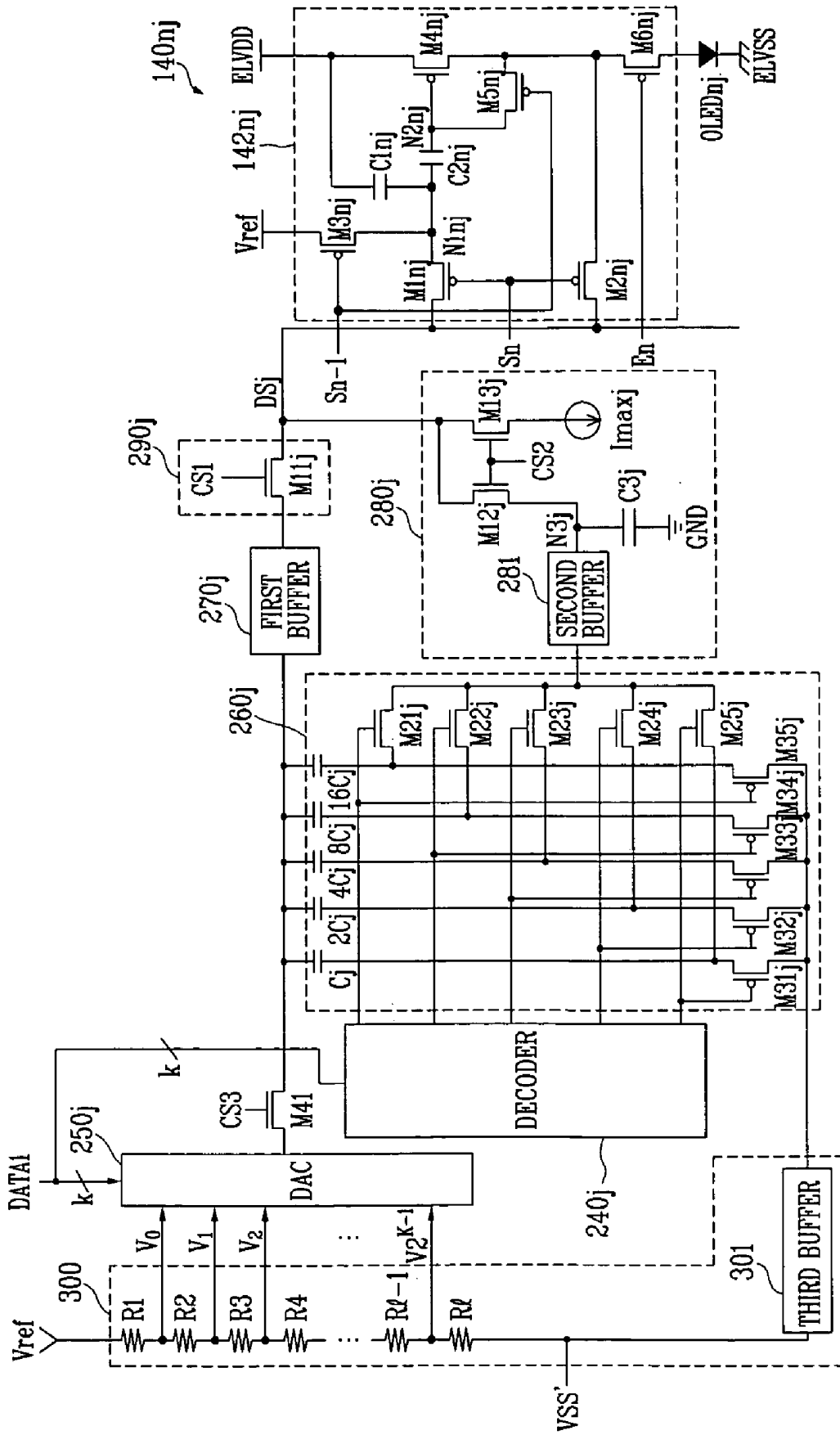

FIG. 9

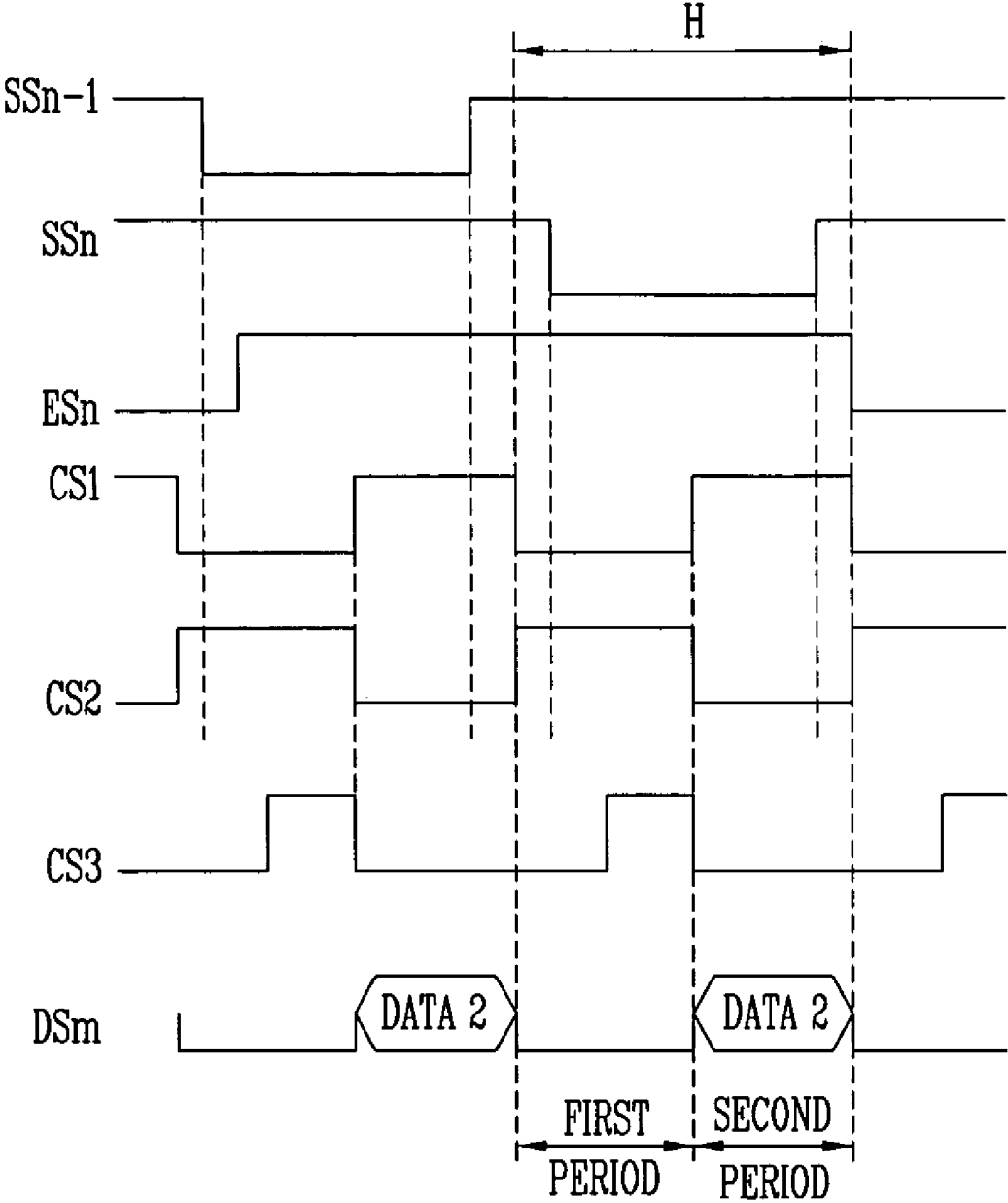

FIG. 10

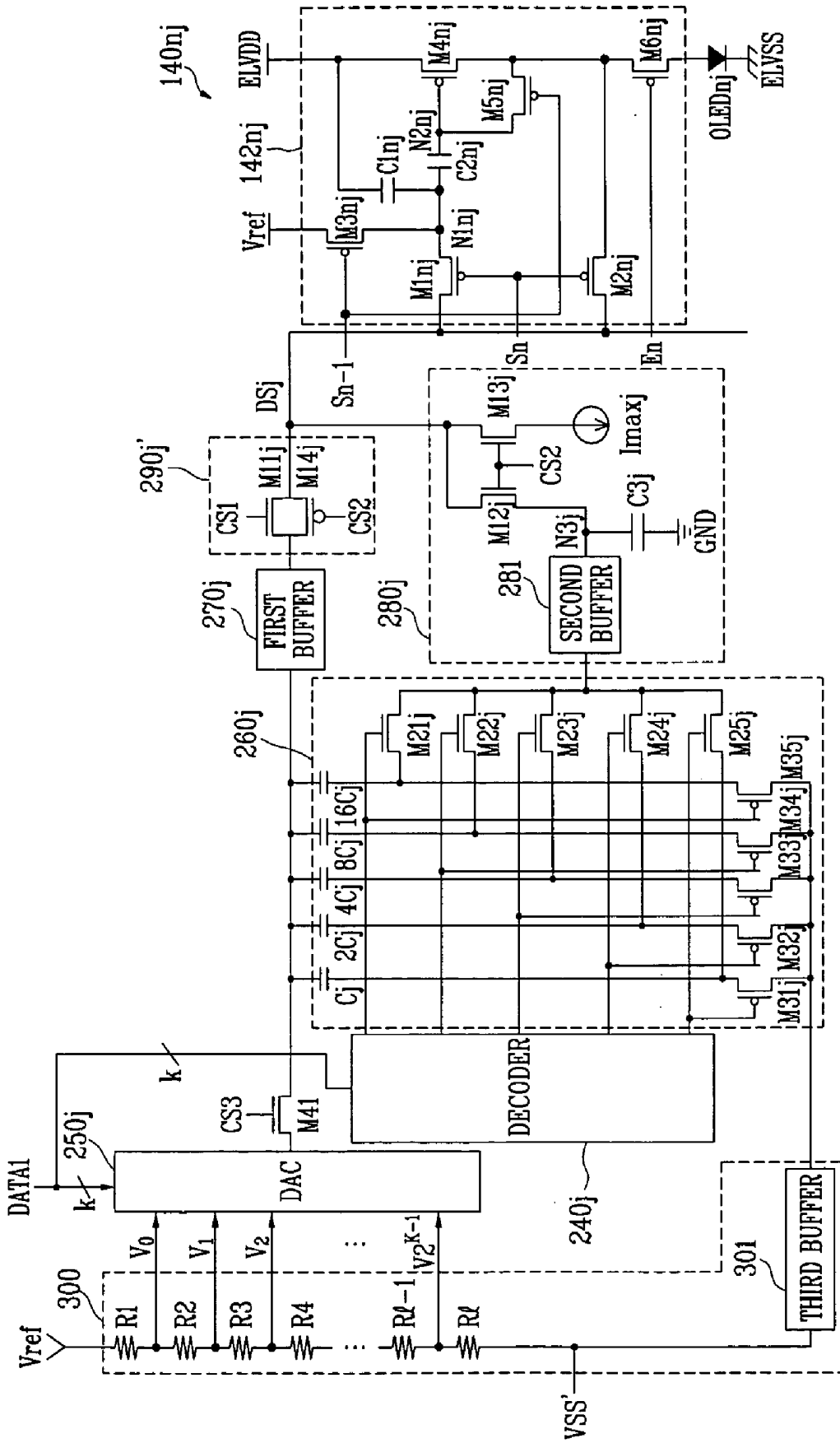
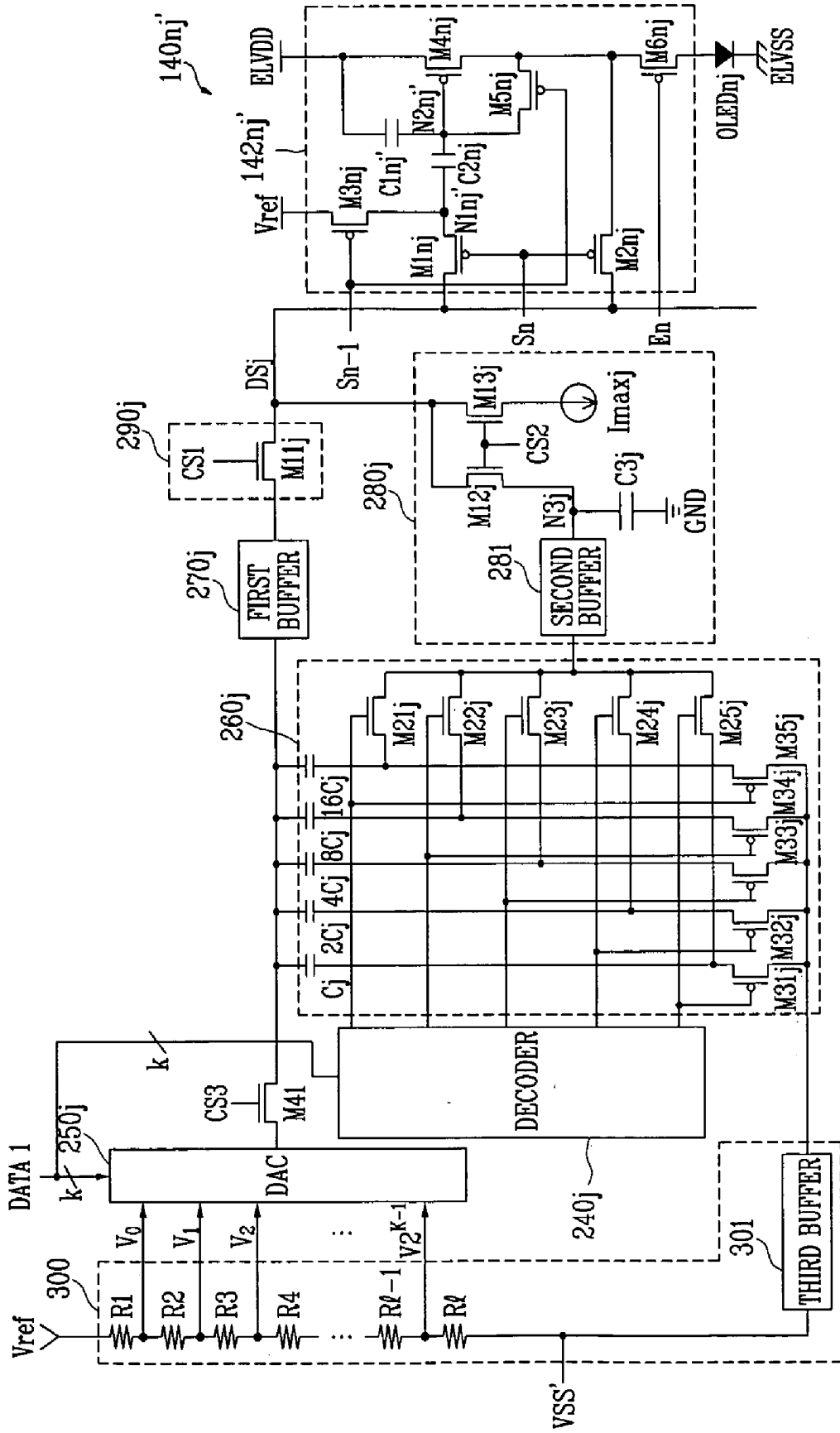

FIG. 11



**DATA DRIVING CIRCUITS AND DRIVING
METHODS OF ORGANIC LIGHT EMITTING
DISPLAYS USING THE SAME**

BACKGROUND

[0001] 1. Field of the Invention

[0002] The present invention relates to data driving circuits, light emitting displays employing such data driving circuits and methods of driving the light emitting display. More particularly, the invention relates to a data driving circuit capable of displaying images with uniform brightness, a light emitting display using such a data driving circuit and a method of driving the light emitting display to display images with uniform brightness.

[0003] 2. Description of Related Art

[0004] Flat panel displays (FPDs), which are generally lighter and more compact than cathode ray tubes (CRTs), are being developed. FPDs include liquid crystal displays (LCDs), field emission displays (FEDs), plasma display panels (PDPs) and light emitting displays.

[0005] Light emitting displays may display images using organic light emitting diodes (OLEDs) that generate light when electrons and holes recombine. Light emitting displays generally have fast response times and consume relatively low amounts of power.

[0006] FIG. 1 illustrates a schematic of the structure of a known light emitting display.

[0007] As shown in FIG. 1, the light emitting display may include a pixel unit 30, a scan driver 10, a data driver 20 and a timing controller 50. The pixel unit 30 may include a plurality of pixels 40 connected to scan lines S1 to Sn and data lines D1 to Dm. The scan driver 10 may drive the scan lines S1 to Sn. The data driver 20 may drive the data lines D1 to Dm. The timing controller 50 may control the scan driver 10 and the data driver 20.

[0008] The timing controller 50 may generate data driving control signals DCS and scan driving control signals SCS based on externally supplied synchronizing signals (not shown). The data driving control signals DCS may be supplied to the data driver 20 and the scan driving control signals SCS may be supplied to the scan driver 10. The timing controller 50 may supply data DATA to the data driver 20 in accordance with externally supplied data (not shown).

[0009] The scan driver 10 may receive the scan driving control signals SCS from the timing controller 50. The scan driver 10 may generate scan signals (not shown) based on the received scan driving control signals SCS. The generated scan signals may be sequentially supplied to the pixel unit 30 via the scan lines S1 to Sn.

[0010] The data driver 20 may receive the data driving control signals DCS from the timing controller 50. The data driver 20 may generate data signals (not shown) based on the received data DATA and data driving control signals DCS. Corresponding ones of the generated data signals may be supplied to the data lines D1 to Dm in synchronization with respective ones of the scan signals being supplied to the scan lines S1 to Sn.

[0011] The pixel unit 30 may be connected to a first power source ELVDD for supplying a first voltage VDD and a second power source ELVSS for supplying a second voltage VSS to the pixels 40. The pixels 40, together with the first voltage VDD signal and the second voltage VSS signal, may control the currents that flow through respective OLEDs in accordance with the corresponding data signals. The pixels 40 may thereby generate light based on the first voltage VDD signal, the second voltage VSS signal and the data signals.

[0012] In known light emitting displays, each of the pixels 40 may include a pixel circuit including at least one transistor for selectively supplying the respective data signal and the respective scan signal for selectively turning on and turning off the respective pixel 40 of the light emitting display.

[0013] Each pixel 40 of a light emitting display is to generate light of predetermined brightness in response to various values of the respective data signals. For example, when the same data signal is applied to all the pixels 40 of the display, it is generally desired for all the pixels 40 of the display to generate the same brightness. The brightness generated by each pixel 40 is not, however, only dependent on the data signal, but is also dependent on characteristics of each pixel 40, e.g., threshold voltage of each transistor of the pixel circuit.

[0014] Generally, there are variations in threshold voltage and/or electron mobility from transistor to transistor such that different transistors have different threshold voltages and electron mobilities. The characteristics of transistors may also change over time and/or usage. For example, the threshold voltage and electron mobility of a transistor may be dependent on the on/off history of the transistor.

[0015] Therefore, in a light emitting display, the brightness generated by each pixel in response to respective data signals depends on the characteristics of the transistor(s) that may be included in the respective pixel circuit. Such variations in threshold voltage and electron mobility may prevent and/or hinder the uniformity of images being displayed. Thus, such variations in threshold voltage and electron mobility may also prevent the display of an image with a desired brightness.

[0016] Although it may be possible to at least partially compensate for differences between threshold voltages of the transistors included in the pixels by controlling the structure of the pixel circuits of the pixels 40, circuits and methods capable of compensating for the variations in electron mobility are still needed. OLEDs that are capable of displaying images with uniform brightness irrespective of variations in electron mobility are also desired.

SUMMARY OF THE INVENTION

[0017] The present invention is therefore directed to a data driving circuit and a light emitting display using the same, which substantially overcome one or more of the problems due to the limitations and disadvantages of the related art.

[0018] It is therefore a feature of an embodiment of the present invention to provide a data driving circuit capable of driving pixels of a light emitting display to display images with uniform brightness, a light emitting display using the same, and a method of driving the light emitting display.

[0019] At least one of the above and other features and advantages of the present invention may be realized by providing a data driving circuit for driving a pixel of a light emitting display based on externally supplied first data for the pixel, wherein the pixel is electrically connectable to the driving circuit via at a data line, the data driving circuit including a gamma voltage unit generating a plurality of gray scale voltages, a digital-analog converter selecting, as a data signal, one of the plurality of gray scale voltages using k bits of the first data, k being a natural number, a decoder generating p bits of second data using the k bits of the first data, p being a natural number, a current sink receiving a predetermined current from the pixel during a first partial period of a complete period for driving the pixel based on the selected gray scale voltage, a voltage controller controlling a voltage value of the data signal using the second data and a compensation voltage generated based on the predetermined current, and a switching unit supplying the data signal, with the controlled voltage value, to the pixel, the switching unit supplying the data signal during any partial period of the complete period elapsing after the first partial period of the complete period.

[0020] The data driving circuit may include a first transistor that may be disposed between the digital-analog converter and the switching unit, the digital-analog converter may be turned on during a predetermined time of the first partial period to transfer the data signal, with the controlled voltage value, to the switching unit, and a first buffer may be connected between the first transistor and the switching unit.

[0021] The decoder may convert the first data into a binary weighted value to generate the second data. The gamma voltage unit may include a plurality of distribution resistors for generating the gray scale voltages and distributing a reference supply voltage and a first supply voltage, and a second buffer for supplying the first supply voltage to the voltage controller.

[0022] The voltage controller may include p capacitors, each of the p capacitors may have a first terminal that is connected to an electrical path between the first transistor and the first buffer, second transistors respectively connected between a second terminal of each of the p capacitors and the second buffer, and third transistors respectively connected between the second terminal of each of the p capacitors and the current sink, the third transistors may be of a conduction type different from a conduction type of the second transistors. The decoder may turn on the second transistors during the first partial period, and may supply the first supply voltage to the respective second terminals of the p capacitors.

[0023] Capacitances of the p capacitors may be set to binary weighted values. The decoder may turn on and off the third transistors based on a number of bits of the second data and during the second partial period, the decoder selectively controls a supply of the compensation voltage to the respective second terminals of the p capacitors.

[0024] The current sink may include a current source providing the predetermined current, a first transistor disposed between the data line connected to the pixel and the voltage controller, the first transistor may be turned on during the first partial period, a second transistor disposed between the data line and the current source, the second

transistor may be turned on during the first partial period, a capacitor storing the compensation voltage, and a buffer disposed between the first transistor and the voltage controller, the buffer selectively transferring the compensation voltage to the voltage controller.

[0025] A current value of the predetermined current may be equal to a current value of a minimum current flowing through the pixel when the pixel emits light with maximum brightness, and maximum brightness corresponds to a brightness of the pixel when a highest one of the plurality of reset gray scale voltages is applied to the pixel. The switching unit may include at least one transistor which is turned on during the second partial period. The switching unit may include two transistors which are connected so as to form a transmission gate.

[0026] The data driving circuit may include a shift register unit including at least one shift register for sequentially generating a sampling pulse, a sampling latch unit including at least one sampling latch for receiving the first data in response to the sampling pulse, and a holding latch unit including at least one holding latch for receiving the first data stored in the sampling latch and supplying the first data stored in the holding latch to the digital-analog converter and the decoder. The data driving circuit may include a level shifter for selectively modifying a voltage level of the first data stored in the holding latch and supplying the first data to the digital-analog converter and the decoder.

[0027] At least one of the above and other features and advantages of the present invention may be separately realized by providing a light emitting display that receives externally supplied first data and includes a pixel unit including a plurality of pixels connected to n scan lines, a plurality of data lines, and a plurality of emission control lines, a scan driver respectively and sequentially supplying, during each scan cycle, n scan signals to the n scan lines, and for sequentially supplying emission control signals to the plurality of emission control lines, and a data driver receiving a predetermined current from respective ones of the pixels selected by a first scan signal during a first partial period of a complete period, respectively controlling voltage values of data signals using respective compensation voltages generated based on the respective predetermined current and respective second data generated by converting the respective first data into second data using binary weighted values, and respectively supplying the data signals, with the controlled voltage values, to the data lines during a partial period of the complete period that elapses after the first partial period of the respective complete period associated with each of the respective pixels.

[0028] Each of the pixels may be connected to two of the n scan lines, and during each of the scan cycles, a first of the two scan lines receiving a respective one of the n scan signals before a second of the two scan lines receives a respective one of the n scan signals, and each of the pixels may include a first power source, an light emitter receiving current from the first power source, first and second transistors each having a first electrode connected to the respective one of the data lines associated with the pixel, the first and second transistors being turned on when the first of the two scan signals is supplied, a third transistor having a first electrode connected to a reference power source and a second electrode connected to a second electrode of the first

transistor, the third transistor being turned on when the first of the two scans signal is supplied, a fourth transistor, the fourth transistor controlling an amount of current supplied to the light emitter, a first terminal of the fourth transistor being connected to the first power source, and a fifth transistor having a first electrode connected to a gate electrode of the fourth transistor and a second electrode connected to a second electrode of the fourth transistor, the fifth transistor being turned on when the first of the two scan signals is supplied such that the fourth transistor operates as a diode.

[0029] Each of the pixels may include a first capacitor having a first electrode connected to one of a second electrode of the first transistor or the gate electrode of the fourth transistor and a second electrode connected to the first power source, and a second capacitor having a first electrode connected to the second electrode of the first transistor and a second electrode connected to the gate electrode of the fourth transistor.

[0030] Each of the pixels may include a sixth transistor having a first terminal connected to the second electrode of the fourth transistor and a second terminal connected to the light emitter, the sixth transistor being turned off when the respective emission control signal is supplied, wherein the current sink receives the predetermined current from the pixel during a first partial period of one complete period for driving the pixel, the first partial period occurring before a second partial period of the complete period for driving the pixel, and the sixth transistor is turned on during the second partial period of the complete period for driving the pixel.

[0031] At least one of the above and other features and advantages of the present invention may be separately realized by providing a method for driving a light emitting display that includes selecting, as a data signal, one of a plurality of gray scale voltages based on k bits of externally supplied first data, k being a natural number, converting the first data into a binary weighted value and generating p bits of second data, p being a natural number, receiving predetermined current from a pixel selected by a scan signal during a first partial period of a complete period for driving the pixel based on the selected gray scale voltage, controlling a voltage value of the data signal using the generated second data and a compensation voltage generated when the predetermined current is supplied, and after controlling the voltage value of the data signal, supplying the data signal to the pixel, the data signal being supplied to the pixel during a second partial period of the complete period for driving the pixel.

[0032] The method may further involve generating the plurality of gray scale voltages by distributing a voltage between reference supply voltage and a first supply voltage among a plurality of voltage dividing resistors.

[0033] Controlling the voltage value of the data signal may include supplying a voltage value of the first power source to a first terminal of a each of a plurality of capacitors during the first, and selectively controlling a supply of the compensation voltage to the respective second terminals of the plurality of capacitors based on a number of bits of the second data, during a second partial period of the complete period.

[0034] At least one of the above and other features and advantages of the present invention may be separately

realized by providing a data driving circuit for driving a light emitting display that includes selecting means for selecting, as a data signal, one of a plurality of gray scale voltages based on k bits of externally supplied first data, k being a natural number, converting means for converting the first data into a binary weighted value and generating p bits of second data, p being a natural number, receiving means for receiving predetermined current from a pixel selected by a scan signal during a first partial period of a complete period for driving the pixel based on the selected gray scale voltage, controlling means for controlling a voltage value of the data signal using the generated second data and a compensation voltage generated when the predetermined current is supplied, and after controlling the voltage value of the data signal, supplying the data signal to the pixel, the data signal being supplied to the pixel during a second partial period of the complete period for driving the pixel.

BRIEF DESCRIPTION OF THE DRAWINGS

[0035] These and other features and advantages of the invention will become apparent to those of ordinary skill in the art by describing in detail exemplary embodiments thereof with reference to the attached drawings in which:

[0036] FIG. 1 illustrates a schematic diagram of a known light emitting display;

[0037] FIG. 2 illustrates a schematic diagram of a light emitting display according to an embodiment of the present invention;

[0038] FIG. 3 illustrates a circuit diagram of an exemplary pixel employable in the light emitting display illustrated in FIG. 2;

[0039] FIG. 4 illustrates exemplary waveforms employable for driving the pixel illustrated in FIG. 3;

[0040] FIG. 5 illustrates a circuit diagram of another exemplary pixel employable in the light emitting display illustrated in FIG. 2;

[0041] FIG. 6 illustrates a block diagram of a first embodiment of the data driving circuit illustrated in FIG. 2;

[0042] FIG. 7 illustrates a block diagram of a second embodiment of the data driving circuit illustrated in FIG. 2;

[0043] FIG. 8 illustrates a schematic diagram of a first embodiment of a connection scheme connecting a gamma voltage unit, a digital-to-analog converter, a decoder, a voltage controller, a switching unit and a current sink unit illustrated in FIG. 6, and a pixel illustrated in FIG. 5;

[0044] FIG. 9 illustrates exemplary waveforms employable for driving the pixel, the switching unit and the current sink unit illustrated in FIG. 8;

[0045] FIG. 10 illustrates the connection scheme illustrated in FIG. 8 employing another embodiment of a switching unit; and

[0046] FIG. 11 illustrates a schematic diagram of a second embodiment of a connection scheme connecting the gamma voltage unit, the digital-to-analog converter, the decoder, the voltage controller, the switching unit and the current sink unit illustrated in FIG. 6, and the pixel illustrated in FIG. 5.

DETAILED DESCRIPTION OF THE INVENTION

[0047] Korean Patent Application No. 2005-0070438, filed on Aug. 1, 2005, in the Korean Intellectual Property

Office, and entitled, "Data Driving Circuit and Driving Method of Organic Light Emitting Display Using the Same," is incorporated by reference herein in its entirety.

[0048] The present invention will now be described more fully hereinafter with reference to the accompanying drawings, in which exemplary embodiments of the invention are shown. The invention may, however, be embodied in different forms and should not be construed as limited to the embodiments set forth herein. Rather, these embodiments are provided so that this disclosure will be thorough and complete, and will fully convey the scope of the invention to those skilled in the art. Like reference numerals refer to like elements throughout.

[0049] Hereinafter, exemplary embodiments of the present invention will be described with reference to FIGS. 2 to 11. In data driving circuits, data driving methods and light emitting displays employing one or more aspects of the invention, because a voltage of a data signal is reset using a compensation voltage generated when current sinks from a respective pixel, uniform images can be displayed regardless of electron mobility, threshold voltages, etc. of transistors.

[0050] FIG. 2 illustrates a schematic diagram of a light emitting display according to an embodiment of the present invention.

[0051] As shown in FIG. 2, the light emitting display may include a scan driver 110, a data driver 120, a pixel unit 130 and a timing controller 150. The pixel unit 130 may include a plurality of pixels 140. The pixel unit 130 may include $n \times m$ pixels 140 arranged, for example, in n rows and m columns, where n and m may each be integers. The pixels 140 may be connected to scan lines $S1$ to S_n , emission control lines $E1$ to E_n and data lines $D1$ to D_m . The pixels 140 may be respectively formed in the regions partitioned by the emission control lines E_n1 to E_n and the data lines $D1$ to D_m . The scan driver 110 may drive the scan lines $S1$ to S_n and the emission control lines $E1$ to E_n . The data driver 120 may drive the data lines $D1$ to D_m . The timing controller 150 may control the scan driver 110 and the data driver 120. The data driver 120 may include one or more data driving circuits 200.

[0052] The timing controller 150 may generate data driving control signals DCS and scan driving control signals SCS in response to externally supplied synchronizing signals (not shown). The data driving control signals DCS generated by the timing controller 150 may be supplied to the data driver 120. The scan driving control signals SCS generated by the timing controller 150 may be supplied to the scan driver 110. The timing controller 150 may supply first data DATA1 to the data driver 120 in accordance with the externally supplied data (not shown).

[0053] The scan driver 110 may receive the scan driving control signals SCS from the timing controller 150. The scan driver 110 may generate scan signals $SS1$ to SS_n based on the received scan driving control signals SCS and may sequentially and respectively supply the scan signals $SS1$ to SS_n to the scan lines $S1$ to S_n . The scan driver 110 may sequentially supply emission control signals $ES1$ to ES_n to the emission control lines $E1$ to E_n . Each of the emission control signals $ES1$ to ES_n may be supplied, e.g., changed from a low voltage signal to a high voltage signal, such that an "on" emission control signal, e.g., a high voltage signal,

at least partially overlaps at least two of the scan signals $SS1$ to SS_n . Therefore, in embodiments of the invention, a pulse width of the emission control signals $ES1$ to ES_n may be equal to or larger than a pulse width of the scan signals $SS1$ to SS_n .

[0054] The data driver 120 may receive the data driving control signals DCS from the timing controller 150. The data driver 120 may generate data signals $DS1$ to DS_m based on the received data driving control signals DCS and the first data DATA1. The generated data signals $DS1$ to DS_m may be supplied to the data lines $D1$ to D_m in synchronization with the scan signals $SS1$ to SS_n supplied to the scan lines $S1$ to S_n . For example, when the 1st scan signal $SS1$ is supplied, the generated data signals $DS1$ to DS_m corresponding to the pixels 140(1)(1 to m) may be synchronously supplied to the 1st to the m -th pixels in the 1st row via the data lines $D1$ to D_m , and when the n th scan signal SS_n is supplied, the generated data signals $DS1$ to DS_m corresponding to the pixels 140(n)(1 to m) may be synchronously supplied to the 1st to the m -th pixels in the n -th row via the data lines $D1$ to D_m .

[0055] The data driver 120 may supply predetermined currents to the data lines $D1$ to D_m during a first period of one horizontal period 1H for driving one or more of the pixels 140. For example, one horizontal period 1H may correspond to a complete period associated with one of the scan signals $SS1$ to SS_n and a corresponding one of the data signals $DS1$ to DS_m being supplied to the respective pixel 140 in order to drive the respective pixel 140. The data driver 120 may supply predetermined voltages to the data lines $D1$ to D_m during a second period of the one horizontal period. For example, one horizontal period 1H may correspond to a complete period associated with one of the scan signals $SS1$ to SS_n and a corresponding one of the data signals $DS1$ to DS_m being supplied to the respective pixel 140 in order to drive the respective pixel 140. In embodiments of the invention, the data driver 120 may include at least one data driving circuit 200 for supplying such predetermined currents and predetermined voltages during the first and second periods of one horizontal period 1H. In the following description, the predetermined voltages that may be supplied to the data lines $D1$ to D_m during the second period will be referred to as the data signals $DS1$ to DS_m .

[0056] The pixel unit 130 may be connected to a first power source ELVDD for supplying a first voltage VDD, a second power source ELVSS for supplying a second voltage VSS and a reference power source ELVref for supplying a reference voltage Vref to the pixels 140. The first power source ELVDD, the second power source ELVSS and the reference power source ELVref may be externally provided. The pixels 140 may receive the first voltage VDD signal and the second voltage VSS signal, and may control the currents that flow through respective light emitting devices/materials, e.g., OLEDs, in accordance with the data signals $DS1$ to DS_m that may be supplied by the data driver 120 to the pixels 140. The pixels 140 may thereby generate light components corresponding to the received first data DATA1.

[0057] Some or all of the pixels 140 may receive the first voltage VDD signal, the second voltage VSS signal and the reference voltage Vref signal from the respective first, second and reference power sources ELVDD, ELVSS and ELVref. The pixels 140 may compensate for a voltage drop

in the first voltage VDD signal and/or threshold voltage(s) using the reference voltage Vref signal. The amount of compensation may be based on a difference between voltage values of the reference voltage Vref signal and the first voltage VDD signal respectively supplied by the reference power source ELVref and the first power source ELVDD. The pixels 140 may supply respective currents from the first power source ELVDD to the second power source ELVSS via, e.g., the OLEDs in response to the respective data signals DS1 to DS_m. In embodiments of the invention, each of the pixels 140 may have, for example, the structure illustrated in FIG. 3 or 5.

[0058] FIG. 3 illustrates a circuit diagram of an nm-th exemplary pixel 140_{nm} employable in the light emitting display illustrated in FIG. 2. For simplicity, FIG. 3 illustrates the nm-th pixel that may be the pixel provided at the intersection of the n-th row of scan lines S_n and the m-th row of data lines D_m. The nm-th pixel 140_{nm} may be connected to the m-th data line D_m, the n-1th and nth scan lines S_{n-1} and S_n and the nth emission control line E_n. For simplicity, FIG. 3 only illustrates one exemplary pixel 140_{nm}. In embodiments of the invention, the structure of the exemplary pixel 140_{nm} may be employed for all or some of the pixels 140 of the light emitting display.

[0059] Referring to FIG. 3, the nm-th pixel 140_{nm} may include a light emitting material/device, e.g., OLED_{nm}, and an nm-th pixel circuit 142_{nm} for supplying current to the associated light emitting material/device.

[0060] The nm-th OLED_{nm} may generate light of a pre-determined color in response to the current supplied from the nm-th pixel circuit 142_{nm}. The nm-th OLED_{nm} may be formed of, e.g., organic material, phosphor material and/or inorganic material.

[0061] In embodiments of the invention, the nm-th pixel circuit 142_{nm} may generate a compensation voltage for compensating for variations within and/or among the pixels 140 such that the pixels 140 may display images with uniform brightness. The nm-th pixel circuit 142_{nm} may generate the compensation voltage using a previously supplied scan signal of the scan signals SS1 to SS_n during each scan cycle. In embodiments of the invention, one scan cycle may correspond to scan signals SS1 to SS_n being sequentially supplied. Thus, in embodiments of the invention, during each cycle, the n-1th scan signal SS_{n-1} may be supplied prior to the nth scan signal SS_n and when the n-1th scan signal SS_{n-1} is being supplied to the n-1th scan line of the light emitting display, the nm-th pixel circuit 142_{nm} may employ the n-1th scan signal SS_{n-1} to generate a compensation voltage. For example, the second pixel in the second column, i.e., the pixel 140₂₂, may generate a compensation voltage using the first scan signal SS1.

[0062] The compensation voltage may compensate for a voltage drop in a source voltage signal and/or a voltage drop resulting from a threshold voltage of the transistor of the nm-th pixel circuit 142_{nm}. For example, the nm-th pixel circuit 142_{nm} may compensate for a voltage drop of the first voltage VDD signal and/or a threshold voltage of a transistor, e.g., a threshold voltage of a fourth transistor M4_{nm} of the pixel circuit 142_{nm} based on the compensation voltage that may be generated using a previously supplied scan line during the same scan cycle.

[0063] In embodiments of the invention, the pixel circuit 142_{nm} may compensate for a drop in the voltage of the first

power source ELVDD and the threshold voltage of the fourth transistor M4_{nm} when the n-1th scan signal SS_{n-1} is supplied to the n-1th scan line S_{n-1}, and may charge the voltage corresponding to the data signal DS_m when the nth scan signal SS_n is supplied to the nth scan line S_n. In embodiments of the invention, the pixel circuit 142_{nm} may include first to sixth transistors M1_{nm} to M6_{nm}, a first capacitor C1_{nm} and a second capacitor C2_{nm} to generate the compensation voltage and to drive the light emitting material/device.

[0064] A first electrode of the first transistor M1_{nm} may be connected to the data line D_m and a second electrode of the first transistor M1_{nm} may be connected to a first node N1_{nm}. A gate electrode of the first transistor M1_{nm} may be connected to the nth scan line S_n. The first transistor M1_{nm} may be turned on when the nth scan signal SS_n is supplied to the nth scan line S_n. When the first transistor M1_{nm} is turned on, the data line D_m may be electrically connected to the first node N1_{nm}.

[0065] A first electrode of the first capacitor C1_{nm} may be connected to the first node N1_{nm} and a second electrode of the first capacitor C1_{nm} may be connected to the first power source ELVDD.

[0066] A first electrode of the second transistor M2_{nm} may be connected to the data line D_m and a second electrode of the second transistor M2_{nm} may be connected to a second electrode of the fourth transistor M4_{nm}. A gate electrode of a second transistor M2_{nm} may be connected to the nth scan line S_n. The second transistor M2_{nm} may be turned on when the nth scan signal SS_n is supplied to the nth scan line S_n. When the second transistor M2_{nm} is turned on, the data line D_m may be electrically connected to the second electrode of the fourth transistor M4_{nm}.

[0067] A first electrode of the third transistor M3_{nm} may be connected to the reference power source ELVref and a second electrode of the third transistor M3_{nm} may be connected to the first node N1_{nm}. A gate electrode of the third transistor M3_{nm} may be connected to the n-1th scan line S_{n-1}. The third transistor M3_{nm} may be turned on when the n-1th scan signal SS_{n-1} is supplied to the n-1th scan line S_{n-1}. When the third transistor M3_{nm} is turned on, the reference voltage Vref may be electrically connected to the first node N1_{nm}.

[0068] A first electrode of the fourth transistor M4_{nm} may be connected to the first power source ELVDD and the second electrode of the fourth transistor M4_{nm} may be connected to a first electrode of the sixth transistor M6_{nm}. A gate electrode of the fourth transistor M4_{nm} may be connected to the second node N2_{nm}.

[0069] A first electrode of the second capacitor C2_{nm} may be connected to the first node N1_{nm} and a second electrode of the second capacitor C2_{nm} may be connected to the second node N2_{nm}.

[0070] In embodiments of the invention, the first and second capacitors C1_{nm} and C2_{nm} may be charged when the n-1th scan signal SS_{n-1} is supplied. In particular, the first and second capacitors C1_{nm} and C2_{nm} may be charged and the fourth transistor M4_{nm} may supply a current corresponding to a voltage at the second node N2_{nm} to the first electrode of the sixth transistor M6_{nm}.

[0071] A second electrode of the fifth transistor $M5_{nm}$ may be connected to the second node $N2_{nm}$ and a first electrode of the fifth transistor $M5_{nm}$ may be connected to the second electrode of the fourth transistor $M4_{nm}$. A gate electrode of the fifth transistor $M5_{nm}$ may be connected to the $n-1$ th scan line S_{n-1} . The fifth transistor $M5_{nm}$ may be turned on when the $n-1$ th scan signal SS_{n-1} is supplied to the $n-1$ th scan line S_{n-1} so that current flows through the fourth transistor $M4_{nm}$. Therefore, the fourth transistor $M4_{nm}$ may operate as a diode.

[0072] The first electrode of the sixth transistor $M6_{nm}$ may be connected to the second electrode of the fourth transistor $M4_{nm}$ and a second electrode of the sixth transistor $M6_{nm}$ may be connected to an anode electrode of the nm -th OLED $_{nm}$. A gate electrode of the sixth transistor $M6_{nm}$ may be connected to the n th emission control line E_n . The sixth transistor $M6_{nm}$ may be turned off when an emission control signal ES_n is supplied, e.g., a high voltage signal, to the n th emission control line E_n and may be turned on when no emission control signal, e.g., a low voltage signal, is supplied to the n th emission control line E_n .

[0073] In embodiments of the invention, the emission control signal ES_n supplied to the n th emission control line E_n may be supplied to at least partially overlap both the $n-1$ th scan signal SS_{n-1} that may be supplied to the $n-1$ th scan line S_{n-1} and the n th scan signal SS_n that may be supplied to n th scan line S_n . Therefore, the sixth transistor $M6_{nm}$ may be turned off when the $n-1$ th scan signal SS_{n-1} is supplied, e.g., a low voltage signal is supplied, to the $n-1$ th scan line S_{n-1} and the n th scan signal SS_n is supplied, e.g., a low voltage signal is supplied, to the n th scan line S_n so that a predetermined voltage may be charged in the first and second capacitors $C1_{nm}$ and $C2_{nm}$. The sixth transistor $M6_{nm}$ may be turned on during other times to electrically connect the fourth transistor $M4_{nm}$ and the nm -th OLED $_{nm}$ to each other. In the exemplary embodiment shown in FIG. 3, the transistors $M1_{nm}$ to $M6_{nm}$ are PMOS transistors, which may turn on when a low voltage signal is supplied to the respective gate electrode and may turn on when a high voltage signal is supplied to the respective gate electrode. However, the present invention is not limited to PMOS devices.

[0074] In the pixel illustrated in FIG. 3, because the reference power source ELV_{ref} does not supply current to the pixels **140**, a drop in the voltage of the reference voltage V_{ref} may not occur. Therefore, it is possible to maintain the voltage value of the reference voltage V_{ref} signal uniform regardless of the positions of the pixels **140**. In embodiments of the invention, the voltage value of the reference voltage V_{ref} may be equal to or different from the first voltage $ELVDD$.

[0075] FIG. 4 illustrates exemplary waveforms that may be employed for driving the exemplary nm -th pixel **140** illustrated in FIG. 3. As shown in FIG. 4, each horizontal period $1H$ for driving the nm -th pixel **140** may be divided into a first period and a second period. During the first period, predetermined currents (PCs) may respectively flow through the data lines $D1$ to D_m . During the second period, the data signals $DS1$ to DS_m may be supplied to the respective pixels **140** via the data lines $D1$ to D_m . During the first period, the respective PCs may be supplied from each of the pixel(s) **140** to a data driving circuit **200** that may be

capable of functioning, at least in part, as a current sink. During the second period, the data signals $DS1$ to DS_m may be supplied from the data driving circuit **200** to the pixel(s) **140**. For simplicity, in the following description, it will be assumed that, at least initially, i.e., prior to any voltage drop that may result during operation of the pixels **140**, the voltage value of the reference voltage V_{ref} signal is equal to the voltage value of the first voltage VDD signal.

[0076] Exemplary methods of operating the nm -th pixel circuit **142** $_{nm}$ of the nm -th pixel **140** $_{nm}$ of the pixels **140** will be described in detail with reference to FIGS. 3 and 4. First, the $n-1$ th scan signal SS_{n-1} may be supplied to the $n-1$ th scan line S_{n-1} to control the on/off operation of the m pixels that may be connected to the $n-1$ th scan line S_{n-1} . When the scan signal SS_{n-1} is supplied to the $n-1$ th scan line S_{n-1} , the third and fifth transistors $M3_{nm}$ and $M5_{nm}$ of the nm -th pixel circuit **142** $_{nm}$ of the nm pixel **140** $_{nm}$ may be turned on. When the fifth transistor $M5_{nm}$ is turned on, current may flow through the fourth transistor $M4_{nm}$ so that the fourth transistor $M4_{nm}$ may operate as a diode. When the fourth transistor $M4_{nm}$ operates as a diode, the voltage value of the second node $N2_{nm}$ may correspond to a difference between the threshold voltage of the fourth transistor $M4_{nm}$ and the voltage of the first voltage VDD signal being supplied by the first power source $ELVDD$.

[0077] More particularly, when the third transistor $M3_{nm}$ is turned on, the reference voltage V_{ref} signal from the reference power source ELV_{ref} may be applied to the first node $N1_{nm}$. The second capacitor $C2_{nm}$ may be charged with a voltage corresponding to the difference between the first node $N1_{nm}$ and the second node $N2_{nm}$. In embodiments of the invention in which the reference voltage V_{ref} signal from the reference power source ELV_{ref} and the first voltage VDD from the first power source $ELVDD$ may, at least initially, i.e., prior to any voltage drop that may result during operation of the pixels **140**, be equal, the voltage corresponding to the threshold voltage of the fourth transistor $M4_{nm}$ may be charged in the second capacitor $C2_{nm}$. In embodiments of the invention in which a predetermined drop in voltage of the first voltage VDD signal occurs, the threshold voltage of the fourth transistor $M4_{nm}$ and a voltage corresponding to the magnitude of the voltage drop of the first power source $ELVDD$ may be charged in the second capacitor $C2_{nm}$.

[0078] In embodiments of the invention, during the period where the $n-1$ th scan signal SS_{n-1} may be supplied to the $n-1$ th scan line S_{n-1} , a predetermined voltage corresponding to the sum of the voltage corresponding to the voltage drop of the first voltage VDD signal and the threshold voltage of the fourth transistor $M4_{nm}$ may be charged in the second capacitor $C2_{nm}$. By storing the voltage corresponding to a sum of the voltage drop of the first voltage VDD signal from the first power source $ELVDD$ and the threshold voltage of the fourth transistor $M4_{nm}$ during operation of the respective $n-1$ pixel of in the m -th column, it is possible to later utilize the stored voltage to compensate for both the voltage drop of the first voltage VDD signal and the threshold voltage during operation of the respective nm -th pixel **140** $_{nm}$.

[0079] In embodiments of the invention, the voltage corresponding to the sum of the threshold voltage of the fourth transistor $M4_{nm}$ and the difference between the reference

voltage signal V_{ref} and the first voltage VDD signal may be charged in the second capacitor C_{2nm} before the n th scan signal SS_n is supplied to the n th scan line S_n . When the n th scan signal SS_n is supplied to the n th scan line S_n , the first and second transistors M_{1nm} and M_{2nm} may be turned on. During the first period of one horizontal period, when the second transistor M_{2nm} of the pixel circuit $142nm$ of the nm -th pixel $140nm$ is turned on, the PC may be supplied from the nm -th pixel $140nm$ to the data driving circuit **200** via the data line D_m . In embodiments of the invention, the PC may be supplied to the data driving circuit **200** via the first power source ELVDD, the fourth transistor M_{4nm} , the second transistor M_{2nm} and the data line D_m . A predetermined voltage may then be charged in the first and second capacitors C_{1nm} and C_{2nm} in response to the supplied PC.

[0080] The data driving circuit **200** may reset a voltage of a gamma voltage unit (not shown) based on a predetermined voltage value, i.e., compensation voltage that may be generated when the PC sinks, as described above. The reset voltage from the gamma voltage unit (not shown) may be used to generate the data signals DS_1 to DS_m to be respectively supplied to the data lines D_1 to D_m .

[0081] In embodiments of the invention, the generated data signals DS_1 to DS_m may be respectively supplied to the respective data lines D_1 to D_m during the second period of the one horizontal period. More particularly, e.g., the respective generated data signal DS_m may be supplied to the respective first node N_{1nm} via the first transistor M_{1nm} during the second period of the one horizontal period. Then, the voltage corresponding to difference between the data signal DS_m and the first power source ELVDD may be charged in the first capacitor C_{1nm} . The second node N_{2nm} may then float and the second capacitor C_{2nm} may maintain the previously charged voltage.

[0082] In embodiments of the invention, during the period when the $n-1$ pixel in the m -th column is being controlled and the scan signal SS_{n-1} is being supplied to the previous scan line S_{n-1} , a voltage corresponding to the threshold voltage of the fourth transistor M_{4nm} and the voltage drop of the first voltage VDD signal from the first power source ELVDD may be charged in the second capacitor C_{2nm} of the nm -th pixel $140nm$ to compensate for the voltage drop of the first voltage VDD signal from the first power source ELVDD and the threshold voltage of the fourth transistor M_{4nm} .

[0083] In embodiments of the invention, during the period when the n -th scan signal SS_n is supplied to the n -th scan line S_n , the voltage of the gamma voltage unit (not shown) may be reset so that the electron mobility of the transistors included in the respective n -th pixels $140n$ associated with each data line D_1 to D_m may be compensated for and the respective generated data signals DS_1 to DS_m may be supplied to the n -th pixels $140n$ using the respective reset gamma voltages. Therefore, in embodiments of the invention, non-uniformity in the threshold voltages of the transistors and the electron mobility may be compensated, and images with uniform brightness may be displayed. Processes for resetting the voltage of the gamma voltage unit will be described below.

[0084] FIG. 5 illustrates another exemplary embodiment of an nm -th pixel $140nm'$ employable by the light emitting display illustrated in FIG. 2. The structure of the nm -th pixel $140nm'$ illustrated in FIG. 5 is substantially the same as the

structure of the nm -th pixel $140nm$ illustrated in FIG. 3, but for the arrangement of a first capacitor C_{1nm}' in a pixel circuit $142nm'$ and respective connections to a first node N_{1nm}' and a second node N_{2nm}' . In the exemplary embodiment illustrated in FIG. 5, a first electrode of the first capacitor C_{1nm}' may be connected to the second node N_{2nm}' and a second electrode of the first capacitor C_{1nm}' may be connected to the first power source ELVDD. A first electrode of the second capacitor C_{2nm} may be connected to the first node N_{1nm}' and a second electrode of the second capacitor C_{2nm} may be connected to the second node N_{2nm}' . The first node N_{1nm}' may be connected to the second electrode of the first transistor M_{1nm} , the second electrode of the third transistor M_{3nm} and the first electrode of the second capacitor C_{2nm} . The second node N_{2nm}' may be connected to the gate electrode of the fourth transistor M_{4nm} , the second electrode of the fifth transistor M_{5nm} , the first electrode of the first capacitor C_{1nm}' and the second electrode of the second capacitor C_{2nm} .

[0085] In the following description, the same reference numerals employed above in the description of the nm -th pixel $140nm$ shown in FIG. 3 will be employed to describe like features in the exemplary embodiment of the nm -th pixel $140nm'$ illustrated in FIG. 5.

[0086] Exemplary methods for operating the nm -th pixel circuit $142nm'$ of the nm -th pixel $140nm'$ of the pixels 140 will be described in detail with reference to FIGS. 4 and 5. First, during a horizontal period for driving the $n-1$ pixels $140(n-1)(1$ to $m)$, i.e., the pixels arranged in the $(n-1)$ th row, when the $n-1$ th scan signal SS_{n-1} is supplied to the $n-1$ th scan line S_{n-1} , the third and fifth transistors M_{3nm} and M_{5nm} of the n -th pixel(s) $140(n)(1$ to $m)$, i.e., the pixels arranged in the n -th row, may be turned on.

[0087] When the fifth transistor M_{5nm} is turned on, current may flow through the fourth transistor M_{4nm} so that the fourth transistor M_{4nm} may operate as a diode. When the fourth transistor M_{4nm} operates as a diode, a voltage corresponding to a value obtained by subtracting the threshold voltage of the fourth transistor M_{4nm} from the first power source ELVDD may be applied to a second node N_{2nm}' . The voltage corresponding to the threshold voltage of the fourth transistor M_{4nm} may be charged in the first capacitor C_{1nm}' . As shown in FIG. 5, the first capacitor C_{1nm}' may be provided between the second node N_{2nm}' and the first power source ELVDD.

[0088] When the third transistor M_{3nm} is turned on, the voltage of the reference power source ELV_{ref} may be applied to the first node N_{1nm}' . Then, the second capacitor C_{2nm} may be charged with the voltage corresponding to difference between a first node N_{1nm}' and the second node N_{2nm}' . During the period where the $n-1$ th scan signal SS_{n-1} is supplied to the $n-1$ th scan line S_{n-1} and the first and second transistors M_{1nm} and M_{2nm} may be turned off, the data signal DS_m may not be supplied to the nm -th pixel $140nm'$.

[0089] Then, during the first period of the one horizontal period for driving the nm -th pixel $140nm'$, the scan signal SS_n may be supplied to the n th scan line S_n and the first and second transistors M_{1nm} and M_{2nm} may be turned on. When the second transistor M_{2nm} is turned on, during the first period of the one horizontal period, the respective PC may be supplied from the nm -th pixel $140nm'$ to the data

driving circuit **200** via the data line Dm. The PC may be supplied to the data driving circuit **200** via the first power source ELVDD, the fourth transistor M4nm, the second transistor M2nm and the data line Dm. In response to the PC, predetermined voltage may be charged in the first and second capacitors C1nm' and C2nm.

[0090] The data driving circuit **200** may reset the voltage of the gamma voltage unit using the compensation voltage applied in response to the PC to generate the data signal DS using the respectively reset voltage of the gamma voltage unit.

[0091] Then, during the second period of the one horizontal period for driving the nm-th pixel 140nm', the data signal DS_m may be supplied to the first node N1nm'. The predetermined voltage corresponding to the data signal DS_m may be charged in the first and second capacitors C1nm' and C2nm.

[0092] When the data signal DS_m is supplied, the voltage of the first node N1nm' may fall from the voltage Vref of the reference power source ELVref to the voltage of the data signal DS_m. At this time, as the second node N2nm' may be floating, the voltage value of the second node N2nm' may be reduced in response to the amount of voltage drop of the first node N1nm'. The amount of reduction in voltage that may occur at the second node N2nm' may be determined by the capacitances of the first and second capacitors C1nm' and C2nm.

[0093] When the voltage of the second node N2nm' falls, the predetermined voltage corresponding to the voltage value of the second node N2nm' may be charged in the first capacitor C1nm'. When the voltage value of the reference power source ELVref is fixed, the amount of voltage charged in the first capacitor C1nm' may be determined by the data signal DS_m. That is, in the nm-th pixel 140nm' illustrated in FIG. 5, because the voltage values charged in the capacitors C1nm' and C2nm may be determined by the reference power source ELVref and the data signal DS_m, it may be possible to charge a desired voltage irrespective of the voltage drop of the first power source ELVDD.

[0094] In embodiments of the invention, the voltage of the gamma voltage unit may be reset so that the electron mobility of the transistors included in each of the pixels 140 may be compensated for and the respective generated data signal may be supplied using the reset gamma voltage. In embodiments of the invention, non-uniformity among the threshold voltages of the transistors and deviation in the electron mobility of the transistors may be compensated for, thereby enabling images with uniform brightness to be displayed.

[0095] FIG. 6 illustrates a block diagram of a first exemplary embodiment of the data driving circuit illustrated in FIG. 2. For simplicity, in FIG. 6, it is assumed that the data driving circuit **200** has j channels, where j is a natural number equal to or greater than 2.

[0096] As shown in FIG. 6, the data driving circuit **200** may include a shift register unit **210**, a sampling latch unit **220**, a holding latch unit **230**, a decoder unit **240**, a digital-analog converter unit (hereinafter, referred to as a DAC) **250**, a voltage controller unit **260**, a first buffer unit **270**, a current supply unit **280**, a selector **290** and a gamma voltage unit **300**.

[0097] The shift register unit **210** may receive a source shift clock SSC and a source start pulse SSP from the timing controller **150**. The shift register unit **210** may utilize the source shift clock SSC and the source start pulse SSP to sequentially generate j sampling signals while shifting the source start pulse SSP every one period of the source shift clock SSC. The shift register unit **210** may include j shift registers **2101** to **210j**.

[0098] The sampling latch unit **220** may sequentially store the respective first data DATA1 in response to sampling signals sequentially supplied from the shift register unit **210**. The sampling latch unit **220** may include j sampling latches **2201** to **220j** in order to respectively store the j first data DATA1-1 to DATA1-j. Each of the sampling latches **2201** to **220j** may have a magnitude corresponding to a number of bits of the first data DATA1. For example, when the first data DATA1 is k bits, each of the sampling latches **2201** to **220j** may have a magnitude of k bits such that the sampling latches **2201** to **220j** may respectively store k-bits of each of the j first DATA1-1 to DATA1-j.

[0099] The holding latch unit **230** may receive the first data DATA1 from the sampling latch unit **220** to store the first data DATA1 when a source output enable SOE signal is input to the holding latch unit **230**. The holding latch unit **230** may supply the first data DATA1 stored therein to the decoder unit **240** and/or the DAC unit **250** when the SOE signal is input. The holding latch unit **230** may include j holding latches **2301** to **230j** in order to store the j first data DATA1-1 to DATA1-j. Each of the holding latches **2301** to **230j** may have a magnitude corresponding to the number of bits of the first data DATA1. For example, each of the holding latches **2301** to **230j** may have a magnitude of k bits so that the k bits of each of the j first data DATA1-1 to DATA1-j may be respectively stored.

[0100] The decoder unit **240** may include j decoders **2401** through **240j**. Each of the decoders **2401** through **240j** may receive k bits of the respective first data DATA1 and may convert the k bits of the first data DATA1 into p (p is a natural number) bits of second data DATA2. In embodiments of the invention, each of the decoders **2401** through **240j** may generate p bits of second data DATA2 using a binary weighted value.

[0101] In embodiments of the invention, the weighted value of the externally received first data DATA1 may be determined to allow the gamma voltage unit **300** to be set a predetermined voltage. For example, the number of bits of the first data DATA1 allowing a desired gray scale voltage to be selected from a plurality of gray scale voltages may be determined. The plurality of gray scale voltages may be generated by the gamma voltage unit **300**. The decoders **2401** through **240j** may convert k bits of the first data DATA1, corresponding to the gray scale voltages, into respective p bits of second data DATA2-1 to DATA2-j using a binary weighted value. For example, the decoders **2401** through **240j** may generate five bits of the second data DATA2 using eight bits of the first data DATA1.

[0102] The current supply unit **280** may sink predetermined current PC from the respective pixel(s) 140 selected by one of the scan signals SS1 to SS_n. The current supply unit **280** may receive the sinking current via the respective one of the data lines D1 through Dj, during the first period of each horizontal period.

[0103] In embodiments of the invention, the current supply unit **280** may sink an amount of current corresponding to a minimum amount of current that may be employed by the respective light emitter, e.g., OLED, to emit light of maximum brightness. Then, the current supply unit **280** may supply a predetermined compensation voltage to the voltage controller unit **260**. The compensation voltage may be generated while the respective predetermined current PC was sinking. In the exemplary embodiment illustrated in FIG. 6, the current supply unit **280** includes j current sink units **2801** through **280j**.

[0104] The gamma voltage unit **300** may generate predetermined gray scale voltages corresponding to the k bits of the first data DATA1. The gamma voltage unit **300**, as shown in FIG. 8, may include a plurality of distribution or voltage dividing resistors R1 through R/ and may generate 2^k gray scale voltages. The gray scale voltages generated by the gamma voltage unit **300** may be supplied to the DAC unit **250**.

[0105] The DAC unit **250** may include j DACs **2501** through **250j**. The gray scale voltages generated by the gamma voltage unit **300** may be supplied to each of the j DACs **2501** through **250j**. Each of the DACs **2501** through **250j** may select, as a data signal DS, one of the gray scale voltages that may be supplied by the gamma voltage unit **300** based on the respective first data DATA1-1 to DATA1- j supplied from the respective holding latch units **2301** through **230j**. For example, the DACs **2501** to **250j** may respectively select, as a data signal DS, one of the gray scale voltages that may be supplied by the gamma voltage unit **300** based on a number of bits of the respective first data DATA1-1 to DATA1- j .

[0106] The voltage controller unit **260** may include j voltage controllers **2601** through **260j**.

[0107] The voltage controllers **2601** through **260j** may each receive a compensation voltage, e.g., voltage supplied via the respective current sink unit **2801-280j** or the second data DATA2, and a third supply voltage signal VSS'. In embodiments of the invention, a same power source or a different power source may be employed for supplying the second voltage VSS signal and the third supply voltage VSS' signal. The third supply voltage VSS' signal may be supplied to a terminal of the gamma voltage unit **300**. The voltage controllers **2601** through **260j**, which may receive the compensation voltage and/or the second data DATA2, and the third supply voltage VSS' signal, may control a voltage value of the selected data signal DS so that variations among the pixels **140**, such as, variations due to electron mobility, threshold voltage, etc. of transistors included in the respective pixels **140** may be compensated for.

[0108] The first buffer unit **270** may supply the respective data signal DS to the selector **290**. As discussed above, the voltage of the respective data signal may be controlled by the voltage control unit **260**. In embodiments of the invention, the first buffer unit **270** may include j first buffers **2701** through **270j**.

[0109] The selector **290** may control electrical connections between the data lines D1 to Dj and the first buffers **2701** to **270j**. The selector **290** may electrically connect the data lines D1 to Dj and the first buffers **2701** to **270j** to each other during the second period of the one horizontal period.

In embodiments of the invention, the selector **290** may electrically connect the data lines D1 to Dj and the first buffers **2701** to **270j** to each other only during the second period. During periods other than the second period, the selector **290** may keep the data lines D1 to Dj and the first buffers **2701** to **270j** electrically disconnected from each other.

[0110] The selector **290** may include j switching units **2901** to **290j**. The generated respective data signals DS1 to DS j may be respectively supplied from the first buffers **2701** to **270j** to the data lines D1 to Dj via the switching units **2901** to **290j**. In embodiments of the invention, the selection unit **290** may employ other types of switching units. FIG. 10 illustrates another exemplary embodiment of a switching unit **290j'** that may be employed by the selector **290**.

[0111] As shown in FIG. 7, in a second exemplary embodiment, the data driving circuit **200** may include a level shifter **310** that is connected to the holding latch unit **230**. The level shifter **310** may include level registers **3101** to **310j** and may raise the voltage of the first data DATA1 that may be supplied from the holding latch unit **230** and may supply the level-shifted result to the DAC unit **250** and the decoder unit **240**. When the data (not shown) being supplied from an external system to the data driving circuit **200** has high voltage levels, circuit components with high voltage resistant properties should generally be provided, thus, increasing the manufacturing cost. In embodiments of the invention, the data being supplied from an external system to the data driving circuit **200** may have low voltage levels and the low voltage level may be transitioned to a high voltage level by the level shifter **310**.

[0112] FIG. 8 illustrates a first embodiment of a connection scheme for connecting the gamma voltage unit **300**, the DAC **250j**, the decoder **240j**, the voltage controller **260j**, the switching unit **290j**, the current sink unit **280j**, and a pixel **140nj**. For simplicity, FIG. 8 only illustrates one channel, i.e., the j th channel and it is assumed that the data line Dj is connected to an nj -th pixel **140nj** according to the exemplary embodiment of the pixel **140nm** illustrated in FIG. 3.

[0113] As shown in FIG. 8, the gamma voltage unit **300** may include a plurality of distribution resistors R1 to R/. The distribution resistors R1 to R/ may be disposed between the reference supply voltage Vref and the third supply voltage VSS'. The distribution resistors R1 to R/ may distribute or divide a voltage supplied thereto. For example, the distribution resistors R1 to R/ may distribute or divide a voltage between the reference supply voltage Vref and the third supply voltage VSS', and may generate a plurality of gray scale voltages V0 through V 2^k-1 . The distribution resistors R1 to R/ may supply the generated gray scale voltages V0 through V 2^k-1 to the DAC **250j**. The gamma voltage unit **300** may supply the third supply voltage VSS' to the voltage controller **260j** via a third buffer **301**.

[0114] The DAC **250j** may select, as a data signal DS, one of the gray scale voltages V0 through V 2^k-1 , based on a number of the bits of the first data DATA1 and may supply the selected voltage to a first buffer **270j**.

[0115] As shown in FIG. 8, a transistor, e.g., forty-first transistor M41, which may be controlled by a third control signal CS3, may be disposed between the DAC **250j** and the

first buffer **270j**. In such embodiments, the forty-first transistor **M41** may be turned on at a predetermined time during the first period of the horizontal period for driving the pixel **140nj** and the forty-first transistor **M41** may supply the data signal **DSj** supplied from the DAC **250** to the first buffer **270j**. More particularly, for example, the third control signal **CS3** may rise after a second control signal **CS2**, which will be described below, and may fall at the same time as the second control signal **CS2**.

[**0116**] The current sink unit **280j** may include a twelfth transistor **M12j** and a thirteenth transistor **M13j**, a current source **Imaxj**, a third capacitor **C3j**, a third node **N3j**, a ground voltage source **GND** and a second buffer **281**. The twelfth transistor **M12j** and the thirteenth transistor **M13j** may be controlled by the second control signal **CS2**. The current source **Imaxj** may be connected to a first electrode of the thirteenth transistor **M13j**. The third capacitor **C3j** may be connected between the third node **N3j** and the ground voltage source **GND**. The second buffer **281j** may be connected between the third node **N3j** and the voltage controller **260j**.

[**0117**] A gate electrode of the twelfth transistor **M12j** may be connected to a gate electrode of the thirteenth transistor **M13j**. A second electrode of the twelfth transistor **M12j** may be connected to a second electrode of the thirteenth transistor **M13j** and the data line **Dj**. A first electrode of the twelfth transistor **M12j** may be connected to the second buffer **281**. The twelfth transistor **M12j** and the thirteenth transistor **M13j** may be turned on during the first period of each horizontal period **1H**. The twelfth transistor **M12j** and the thirteenth transistor **M13j** may be turned off during the second period of the horizontal period **1H**. The second control signal **CS2** may control the on/off state of the twelfth transistor **M12j** and the thirteenth transistor **M13j**.

[**0118**] During the first period of one horizontal period **1H**, the current source **Imaxj** may receive, from the pixel **140nj**, at least a minimum amount of current that may be supplied to the light emitter, e.g., **OLEDnj**, for the pixel **140nj** to emit light with maximum brightness. As discussed above, the second control signal **CS2** may control the twelfth transistor **M12j** and the thirteenth transistor **M13j** to be on during the first period, thereby allowing the predetermined current **PC** to flow from the pixel **140nj** to the current sink unit **280j**.

[**0119**] The third capacitor **C3j** may store a compensation voltage that may be applied to the third node **N3j** when the current from the pixel **140nj** sinks to the current source **Imaxj**. The third capacitor **C3j** may store the compensation voltage applied to the third node **N3j** during the first period of one horizontal period **1H**, and may maintain the compensation voltage at the third node **N3j** stable even when the twelfth transistor **M12j** and the thirteenth transistor **M13j** are turned off.

[**0120**] The second buffer **281j** may transfer the compensation voltage applied to the third node **N3j** to the voltage controller **260j**.

[**0121**] The decoder **240j** may receive and may convert **k** bits of the first data **DATA1** into **p** bits of second data **DATA2** using a binary weighted value. The decoder **240j** may supply an initialization signal (not shown) to the voltage controller **260j** during the first period of the horizontal period **1H** and the decoder **240j** may supply the **p** bits

of second data **DATA2** to the voltage controller **260j** during the second period of the same horizontal period **1H**. In the following description of exemplary embodiments, for simplicity, it will be assumed that the **p** bits are 5 bits. In embodiments of the invention, **p** may be any integer greater than or equal to zero.

[**0122**] The voltage controller **260j** may receive the compensation voltage and/or the second data **DATA2**, and the third supply voltage **VSS'** and may control the voltage value of the data signal **DSj**. In the description of exemplary embodiments, reference term “**p**” will be equal to five, however, “**p**” may be any integer. To control the voltage value of the data signal **DSj**, the voltage controller **260j** may include **p** capacitors **Cj**, **2Cj**, **4Cj**, **8Cj** and **16Cj**, **p** PMOS transistors **M31j**, **M32j**, **M33j**, **M34j** and **M35j** and **p** NMOS transistors **M21j**, **M22j**, **M23j**, **M24j** and **M25j**. The capacitors **Cj**, **2Cj**, **4Cj**, **8Cj** and **16Cj** may be connected to an electrical path connecting the forty-first transistor **M41** and the first buffer **270j**. The **p** PMOS transistors **M31j**, **M32j**, **M33j**, **M34j** and **M35j** may be connected the third buffer **301** and the **p** capacitors **Cj**, **2Cj**, **4Cj**, **8Cj** and **16Cj**, respectively. The **p** NMOS transistors **M21j**, **M22j**, **M23j**, **M24j** and **M25j** may be connected between the second buffer **281j** and the **p** capacitors **Cj**, **2Cj**, **4Cj**, **8Cj** and **16Cj**, respectively.

[**0123**] Capacitance values of the **p** capacitors **Cj**, **2Cj**, **4Cj**, **8Cj** and **16Cj** may be relative to each other such that the capacitances of the **p** capacitors may increase along the order of 2^0 , 2^1 , 2^2 , 2^3 and 2^4 , respectively. For example, the capacitances of the **p** capacitors **Cj**, **2Cj**, **4Cj**, **8Cj** and **16Cj** may have respective binary weighted values in accordance with the second data **DATA2**.

[**0124**] The **p** PMOS transistors **M31j**, **M32j**, **M33j**, **M34j** and **M35j** may be respectively disposed between the **p** capacitors **Cj**, **2Cj**, **4Cj**, **8Cj** and **16Cj** and the third buffer **301**. The **p** PMOS transistors **M31j**, **M32j**, **M33j**, **M34j** and **M35j** may be turned on when the initialization signal (not shown) is supplied from the decoder **240j**, and the **p** PMOS transistors **M31j**, **M32j**, **M33j**, **M34j** and **M35j** may respectively set a voltage of a terminal of the **p** capacitors **Cj**, **2Cj**, **4Cj**, **8Cj** and **16Cj** to the third supply voltage **VSS'**.

[**0125**] The **p** NMOS transistors **M21j**, **M22j**, **M23j**, **M24j** and **M25j** may be respectively disposed between each of the **p** capacitors **Cj**, **2Cj**, **4Cj**, **8Cj** and **16Cj** and the second buffer **281j**. The **p** NMOS transistors **M21j**, **M22j**, **M23j**, **M24j** and **M25j** may be turned on or off during the second period of one horizontal period **1H** for driving the pixel **140nj** based on the second data **DATA2** generated from the decoder **240j**. The **p** NMOS transistors **M21j**, **M22j**, **M23j**, **M24j** and **M25j** may be controlled to select the respective one/ones of the **p** capacitors **Cj**, **2Cj**, **4Cj**, **8Cj** and **16Cj** based on bit weighted values of the second data **DATA2**. For example, if the bits of the second data **DATA2** generated by the decoder **240j** are set to “00011”, the twenty-fourth transistor **M24j** and the twenty-fifth transistor **M25j** are turned on to apply the compensation voltage, e.g., voltage stored in the third capacitor **C3j**, to terminals of the respective first and second ones, e.g., **Cj** and **2Cj**, of the **p** capacitors. In such embodiments, if bits corresponding to 2^0 and 2^1 have a value “1”, the on/off state of the **p** NMOS transistors **M21j**, **M22j**, **M23j**, **M24j** and **M25j** may be controlled so that a compensation voltage may be applied to respective terminals of the first and second ones **Cj** and **2Cj** of the **p** capacitors **Cj**, **2Cj**,

4Cj, 8Cj and 16Cj. As discussed above, in embodiments of the invention, the first and second ones Cj and 2Cj of the p capacitors Cj, 2Cj, 4Cj, 8Cj and 16Cj, may have capacitances corresponding to 2^0 and 2^1 .

[0126] In embodiments of the invention, the voltage value of the data signal DSj applied to the electrical path between the forty-first transistor M41j and the first buffer 270j may be increased or decreased in accordance with the compensation voltage that may be applied to respective terminals of the p capacitors Cj, 2Cj, 4Cj, 8Cj and 16Cj. More particularly, any increase or decrease in the voltage value of the data signal DSj applied to the electrical path between the forty-first transistor M41j and the first buffer 270j (and later to the data line Dj) may depend on the voltage value of the compensation voltage. Because the voltage value of the data signal DSj may be controlled with the applied compensation voltage, the voltage value of the data signal DSj may be controlled so that variations among the pixels 140 may be compensated for and the pixel unit 130 can display a uniform image.

[0127] For example, because the voltage value of the data signal DSj may be controlled with the applied compensation voltage, variations in electron mobility and/or threshold voltages of transistors included in the pixel 140nj may be compensated for. In embodiments of the invention, because the data driving circuit 200 may control the voltage value of the data signals DS using a compensation voltage generated based on characteristics, e.g., electron mobility, threshold voltage, etc., of the respective pixels 140, the data driving circuit may control the voltage value of the respective data signal DS being supplied to the respective pixels 140 and may can compensate for variations in electron mobility of the transistors.

[0128] As shown in FIG. 8, the first buffer 270j may transfer the data signal DSj applied to the electrical connection between the forty-first transistor M41j and the first buffer 270j to the switching unit 290j.

[0129] The switching unit 290j may include an eleventh transistor M11j. The eleventh transistor M11j may be controlled by the first control signal CS1, as shown in FIGS. 8 and 9. In embodiments of the invention, the eleventh transistor M11j may be turned on during the second period of each horizontal period 1H for driving each of the n pixels in the j-th channel. In such embodiments, the eleventh transistor M11j may be turned off during the first period of each horizontal period 1H for driving each of the n pixels in the j-th channel. Thus, the data signal DSj may supplied to the data line Dj during the second period of the horizontal period 1H and may not be supplied during other periods, e.g., the first period, of a single horizontal period 1H. In embodiments of the invention, the data signal DSj may only be supplied during the second horizontal period of a single horizontal period 1H. In embodiments of the invention, the data signal DSj may never be supplied to the data line Dj during the first period of a single horizontal period 1H.

[0130] FIG. 9 illustrates exemplary waveforms employable for driving the pixel, the switching unit and the current sink unit illustrated in FIG. 8. Exemplary methods for controlling the voltage of data signals DS respectively supplied to the pixels 140 will be described in detail with reference to FIGS. 8 and 9. In the exemplary embodiment illustrated in FIG. 8, the pixel 140nj and the pixel circuit

142nj, according to the exemplary embodiment illustrated in FIG. 3, is provided. In the following description, the same reference numerals employed above in the description of the nm-th pixel 140nm shown in FIG. 3 will be employed to describe like features in the exemplary embodiment of the nj-th pixel 140nj illustrated in FIG. 8.

[0131] First, the scan signal SSn-1 may be supplied to the n-1th scan line Sn-1. When the scan signal SSn-1 is supplied to the n-1th scan line Sn-1, the third and fifth transistors M3nj and M5nj may be turned on. The voltage value obtained by subtracting the threshold voltage of the fourth transistor M4nj from the first power source ELVDD may then be applied to a second node N2nj and the voltage of the reference power source ELVref may be applied to a first node N1nj. The voltage corresponding to the voltage drop of the first power source ELVDD and the threshold voltage of the fourth transistor M4nj may then be charged in the second capacitor C2nj.

[0132] The voltages applied to the first node N1nj and the second node N2nj may be represented by EQUATION1 and EQUATION2.

$$V_{N1}=V_{ref} \quad \text{[EQUATION1]}$$

$$V_{N2}=ELVDD-|V_{thM4}| \quad \text{[EQUATION2]}$$

[0133] In EQUATION1 and EQUATION2, V_{N1} , V_{N2} , and V_{thM4} represent the voltage applied to the first node N1nj, the voltage applied to the second node N2nj, and the threshold voltage of the fourth transistor M4nj, respectively.

[0134] From the time when the scan signal SSn-1 is supplied to the n-1th scan line Sn-1 is turned off, e.g., changed from a low voltage signal to a high voltage signal, to the time when the scan signal SSn is supplied, e.g., changed from a high voltage signal to a low voltage signal, to the nth scan line Snj, the first and second nodes N1nj and N2nj may be floating. Therefore, the voltage value charged in the second capacitor C2nj may not change during that time.

[0135] The n-th scan signal SSn may then be supplied to the nth scan line Sn so that the first and second transistors M1nj and M2nj may be turned on. When the scan signal SSn is being supplied to the nth scan line Sn, during the first period of the one horizontal period when the n-th scan line Sn is being driven, the 12th and 13th transistors M12j and M13j may be turned on. When the 12th and 13th transistors M12j and M13j are turned on, the current that may flow through the current source Imaxj via the first power source ELVDD, the fourth transistor M4nj, the second transistor M2nj, the data line Dj, and the 13th transistor M13j may sink.

[0136] When current flows through the current source Imaxj via the first power source ELVDD, the fourth transistor M4nj and the second transistor M2nj, EQUATION3 may apply.

$$I_{max} = \frac{1}{2} \mu_p C_{ox} \frac{W}{L} (ELVDD - V_{N2} - |V_{thM4}|)^2 \quad \text{[EQUATION3]}$$

[0137] In EQUATION3, μ , C_{ox} , W , and L represent the electron mobility, the capacity of an oxide layer, the width of a channel, and the length of a channel, respectively.

[0138] The voltage applied to the second node $N2nj$ when the current obtained by EQUATION3 flows through the fourth transistor $M4nj$ may be represented by EQUATION4.

$$V_{N2} = ELVDD - \sqrt{\frac{2I_{max} L}{\mu_p C_{ox} W}} - |V_{thM4}| \quad [EQUATION4]$$

[0139] The voltage applied to the first node $N1nj$ may be represented by EQUATION5 by the coupling of the second capacitor $C2nj$.

$$V_{N1} = V_{ref} - \sqrt{\frac{2I_{max} L}{\mu_p C_{ox} W}} = V_{N3} \quad [EQUATION5]$$

[0140] In EQUATION5, the voltage V_{N1} may correspond to the voltage applied to the first node $N1nj$ and the voltage V_{N3} may correspond to the voltage applied to the third node $N3j$. In embodiments of the invention, when current sinks by the current source I_{maxj} , a voltage satisfying EQUATION5 may be applied to the third node $N3j$.

[0141] As seen in EQUATION5, the voltage applied to the third node $N3j$ may be affected by the electron mobility of the transistors included in the pixel $140nj$, which is supplying current to the current source I_{maxj} . Therefore, the voltage value applied to the third node $N3j$ when the current is being supplied to the current source I_{maxj} may vary in each of the pixels **140**, e.g., when the electron mobility varies in each of the pixels **140**.

[0142] During the first period of a horizontal period $1H$ for driving each of the pixels **140**, the DAC **250** may select an h -th one of f gray scale voltages based on the first data $DATA1$ for respective pixels, where h and f are natural numbers. For example, the DAC **250j** may select the h -th one of f gray scale voltages corresponding to the first data $DATA1$ for the nj -th pixel $140nj$. Then, when the forty-first transistor $M41$ is turned on, the DAC **250j** together with the voltage controller **260j** may selectively apply the selected h -th one of the f gray scale voltages, as the data signal DSj , to the electrical connection between the forty-first transistor $M41j$ and the first buffer **270j**. A voltage applied to the electrical connection between the forty-first transistor $M41$ and the first buffer **270j** may be expressed by EQUATION6.

$$V_L = V_{ref} - \frac{h}{f}(V_{ref} - V_{SS}) \quad [EQUATION6]$$

[0143] Meanwhile, as discussed above, the decoder **240j** may supply an initialization signal during the first period of each horizontal period $1H$. The initialization signal may turn on the thirty-first transistor $M31j$, the thirty-second transistor $M32j$, the thirty-third transistor $M33j$, the thirty-fourth transistor $M34j$ and the thirty-fifth transistor $M35j$. Thus, during the first period of each horizontal period $1H$, a voltage of a terminal of each of the p capacitors Cj , $2Cj$, $4Cj$, $8Cj$ and $16Cj$ may be set to a voltage of the third supply voltage VSS' . In embodiments of the invention, the voltage

value of the third supply voltage VSS' may be set lower than the voltage value of the reference supply voltage V_{ref} . For example, the third supply voltage VSS' may be set to an average voltage of compensation voltages that may be generated by the pixels **140** included in the pixel unit **130**.

[0144] After the voltage of the terminal of each of the p capacitors Cj , $2Cj$, $4Cj$, $8Cj$ and $16Cj$ is set to the third supply voltage VSS' , during the second period of the horizontal period, a twenty-first transistor $M21j$, a twenty-second transistor $M22j$, a twenty-third transistor $M23j$, a twenty-fourth transistor $M24j$ and a twenty-fifth transistor $M25j$ may be turned on or off in accordance with the second data $DATA2$ that may be supplied from the decoder **240j**. The decoder **240j** may control the on/off state of the twenty-first transistor $M21j$, the twenty-second transistor $M22j$, the twenty-third transistor $M23j$, the twenty-fourth transistor $M24j$, and the twenty-fifth transistor $M25j$. In particular, the decoder **240j** may control the on/off state of the twenty-first transistor $M21j$, the twenty-second transistor $M22j$, the twenty-third transistor $M23j$, the twenty-fourth transistor $M24j$, and the twenty-fifth transistor $M25j$ to obtain a value approximating to a value of h/f in EQUATION6.

[0145] For example, if the bits of the second data $DATA2$ generated by the decoder **240j** are set to "00011", the twenty-fourth transistor $M24j$ and the twenty-fifth transistor $M25j$ may be turned on to apply a compensation voltage to a terminal of each of the first and second ones Cj and $2Cj$ of the p capacitors. In this example, because the compensation voltage may be applied to a terminal of each of the first and second ones Cj and $2Cj$ of the p capacitors, EQUATION7 can be deduced.

$$\frac{C + 2C}{C + 2C + 4C + 8C + 16C} \equiv \frac{h}{f} \quad [EQUATION7]$$

[0146] More particularly, because the second data $DATA2$ may be derived from the first data $DATA1$, a value satisfying EQUATION7 approximates the value of h/f .

[0147] Meanwhile, if the compensation voltage is applied to at least one of the p capacitors Cj , $2Cj$, $4Cj$, $8Cj$ and $16Cj$, a voltage of the electrical connection between the forty-first transistor $M41$ and the first buffer **270j** may be expressed by EQUATION8.

$$\begin{aligned} V_L &= V_{ref} - \frac{h}{f}(V_{ref} - V_{SS}) + V_{boost} \quad [EQUATION8] \\ V_{boost} &= \frac{h}{f}(V_{N3} - V_{SS}) \\ &= V_{ref} - \frac{h}{f}(V_{ref} - V_{N3}) \\ &= V_{ref} - \frac{h}{f} \sqrt{\frac{2I_{max} L}{\mu_p C_{ox} W}} \end{aligned}$$

[0148] A voltage satisfying EQUATION8 may be supplied to the eleventh transistor $M11j$ via the first buffer **270j**. During the second period of the one horizontal period $1H$, because the eleventh transistor $M11j$ may be turned on, the

voltage supplied to the first buffer **270j** may be supplied to the first node **N1nj** via the eleventh transistor **M11j**, the data line **Dj**, and the first transistor **M1nj**. The voltage satisfying EQUATION8 may be supplied to the first node **N1nj**. A voltage applied to the second node **N2nj** by coupling of the second capacitor **C2nj** can be expressed by EQUATION9.

$$V_{N2} = ELVDD - \frac{h}{f} \sqrt{\frac{2I_{max} L}{\mu_p C_{OX} W}} - |V_{thM4}| \quad [\text{EQUATION9}]$$

[0149] Here, current flowing through the fourth transistor **M4nj** may be expressed by EQUATION10.

$$I_{N4} = \frac{1}{2} \mu_p C_{OX} \frac{W}{L} (ELVDD - V_{N2} - |V_{thM4}|)^2 \quad [\text{EQUATION10}]$$

$$= \frac{1}{2} \mu_p C_{OX} \frac{W}{L} \left(\begin{array}{c} ELVDD - \\ ELVDD - \\ \frac{h}{f} \sqrt{\frac{2I_{max} L}{\mu_p C_{OX} W}} - \\ |V_{thM4}| \\ V_{thM4} \end{array} \right)^2$$

$$= \left(\frac{h}{f} \right)^2 I_{max}$$

[0150] Referring to EQUATION10, in embodiments of the invention, current flowing through the fourth transistor **M4nj** may depend on the respective data signal **DS** supplied to the respective pixel **140** and more particularly, the gray scale voltage generated by the voltage controller **260j**. Therefore, in embodiments of the invention, by supplying a current based on a compensation voltage generated by current sinking from the respective pixel **140nj**, a desired current may be selected and supplied as the respective data signal **DS**, irrespective of threshold voltage, electron mobility, etc. of the transistors, e.g., **M4nj**, of the respective pixel. Thus, embodiments of the invention enable uniform images to be displayed irrespective of variations in electron mobility and threshold voltage within and among the pixels **140** of the pixel unit **130**.

[0151] In embodiments of the invention, as discussed above, different switching units may be employed. FIG. 10 illustrates the connection scheme illustrated in FIG. 8 employing another embodiment of a switching unit **290j**. The exemplary connection scheme illustrated in FIG. 10 is substantially the same as the exemplary connection scheme illustrated in FIG. 8, but for another exemplary embodiment of the switching unit **290j**. In the following description, the same reference numerals employed above will be employed to describe like features in the exemplary embodiment illustrated in FIG. 10.

[0152] As shown in FIG. 10, another exemplary switching unit **290j** may include eleventh and fourteenth transistors **M11j**, **M14j** that may be connected to each other in the form of a transmission gate. The 14th transistor **M14j**, which may be a PMOS type transistor, may receive the second control signal **CS2**. The eleventh transistor **M11j**, which may be a NMOS type transistor, may receive the first control signal

CS1. In such embodiments, when the polarity of the first control signal **CS1** is opposite to the polarity of the second control signal **CS2**, the eleventh and fourteenth transistors **M11j** and **M14j** may be turned on and off at the same time.

[0153] In embodiments of the invention in which the eleventh and fourteenth transistors **M11j** and **M14j** may be connected to each other in the form of the transmission gate. In such embodiments, a voltage-current characteristic curve may be in the form of a straight line and switching error may be minimized.

[0154] FIG. 11 illustrates a second embodiment of a connection scheme for connecting the gamma voltage unit **300**, the DAC **250j**, the decoder **240j**, the voltage controller **260j**, the switching unit **290j**, the current sink unit **280j**, and a pixel **140nj**. For simplicity, FIG. 11 only illustrates one channel, i.e., the *j*th channel and it is assumed that the data line **Dj** is connected to the *nj*-th pixel **140nj** according to the exemplary embodiment of the pixel **140nm** illustrated in FIG. 5.

[0155] Methods for driving pixels **140** of a light emitting display will be described in detail with reference to FIGS. 9 and 11. First, when a scan signal **SSn-1** is supplied to the *n-1*th scan line **Sn-1**, a voltage satisfying EQUATION1 and EQUATION2 may be applied to a first node **N1nj** and a second node **N2nj**, respectively.

[0156] The *n*-th scan signal may be applied to the *n*-th scan line **Sn**. During the first period of a horizontal period **1H** for driving the *nj*-th pixel **140nj**, when the twelfth transistor **M12j** and the thirteenth transistor **M13j** may be turned on, current flowing through the fourth transistor **M4j** may satisfy EQUATION3 and a voltage applied to the second node **N2nj** may satisfy EQUATION4. In the following description, the same reference numerals employed above in the description of the exemplary embodiment illustrated in FIG. 8 will be employed to describe like features in the exemplary embodiment of the connection scheme illustrated in FIG. 11.

[0157] A voltage applied to the first node **N1nj** by coupling of the second capacitor **C2nj** can be expressed by EQUATION11.

$$V_{N1} = V_{ref} - \left(\frac{C1 + C2}{C2} \right) \sqrt{\frac{2I_{max} L}{\mu_p C_{ox} W}} = V_{N3} \quad [\text{EQUATION11}]$$

[0158] Meanwhile, during the first period of the horizontal period for driving the *nj*-th pixel **140nj**, the DAC **250j** may select an *h*-th one of *f* gray scale voltages in accordance with the first data **DATA1**, where *h* and *f* are natural numbers. The DAC **250j** may also supply a gray scale voltage satisfying EQUATION6. The selected *h*-th one of the *f* gray scale voltages may be supplied to first buffer **270j** when the forty-first transistor **M41** is turned on. The selected *h*-th one of the *f* gray scale voltages may be selected, as a respective data signal **DSj** to be supplied to the pixel **140nj** via the data line **Dj**.

[0159] The decoder **240j** may supply an initialization signal to the thirty-first transistor **M31j**, the thirty-second transistor **M32j**, the thirty-third transistor **M33j**, the thirty-fourth transistor **M34j** and the thirty-fifth transistor **M35j** and may thereby turn on each of the *p* transistors **M31j**,

M32j, M33j, M34j and M35j during the first period of the horizontal period 1H for driving the pixel 140nj'. Thus, during the first period of the one horizontal period 1H, a voltage of a terminal of each of the p capacitors Cj, 2Cj, 4Cj, 8Cj and 16Cj may be to the third supply voltage VSS'.

[0160] Then, during the second period of the horizontal period 1H for driving the pixel 140nj', the twenty-first transistor M21j, the twenty-second transistor M22j, the twenty-third transistor M23j, the twenty-fourth transistor M24j and the twenty-fifth transistor M25j may be turned on or off in accordance with the second data DATA2 that may be supplied from the decoder 240j. The decoder 240j may control the turning on/off of the twenty-first transistor M21j, the twenty-second transistor M22j, the twenty-third transistor M23j, the twenty-fourth transistor M24j and the twenty-fifth transistor M25j. In particular, as discussed above, the decoder 240j may control the turning on/off of the twenty-first transistor M21j, the twenty-second transistor M22j, the twenty-third transistor M23j, the twenty-fourth transistor M24j and the twenty-fifth transistor M25j so as to obtain a value approximating to the value of h/f in EQUATION6.

[0161] At this time, a voltage V_L of the electrical connection between the forty-first transistor M41 and the first buffer 270j may be expressed by EQUATION12.

$$\begin{aligned} V_L &= V_{ref} - \frac{h}{f}(V_{ref} - V_{SS}) + V_{boost} & \text{[EQUATION12]} \\ V_{boost} &= \frac{h}{f}(V_{N3} - V_{SS}) \\ &= V_{ref} - \frac{h}{f}(V_{ref} - V_{N3}) \\ &= V_{ref} - \frac{h}{f} \left(\frac{C1 + C2}{C2} \right) \sqrt{\frac{2I_{max} L}{\mu_p C_{OX} W}} \end{aligned}$$

[0162] A voltage satisfying EQUATION12 may be supplied to the eleventh transistor M11j via the first buffer 270j. During the second period of the horizontal period 1H for driving the pixel 140nj', because the eleventh transistor M11j may be turned on, the voltage supplied to the first buffer 270j may be supplied to the first node N1nj' via the eleventh transistor M11j, the data line Dj and the first transistor M1j. In embodiments of the invention, a voltage satisfying EQUATION12 may be supplied to the first node N1nj'.

[0163] A voltage applied to the second node N2nj' by the coupling of the second capacitor C2nj may be expressed by EQUATION9. Accordingly, current flowing through the fourth transistor M4nj may be expressed by EQUATION10. In embodiments of the invention, the current corresponding to the gray scale voltage selected by the DAC 250j may flow to the fourth transistor M4nj irrespective of the threshold voltage and electron mobility of the fourth transistor M4nj. As discussed above, embodiments of the invention enable the display of images with uniform brightness.

[0164] In some embodiments of the invention, e.g., embodiments employing the pixel 140nj' illustrated in FIG. 11, the voltage of the second node N2nj' may change gradually although the voltage of the first node N1nj' may change rapidly, i.e., $(C1+C2)/C2$. When the pixel 140nj'

illustrated in FIG. 11 is employed, a greater voltage range may be set for the voltage generator 240j than a voltage range that may be set for the voltage generator 240j when the pixel 140nj' illustrated in FIG. 8 is employed. As discussed above, when the voltage range of the voltage generator 240j is set to be larger, it is possible to reduce the influence of the switching error of the 11th transistor M11j and the first transistor M1nj.

[0165] Accordingly, the pixel structure 140nj' shown in FIG. 5 can extend an available voltage range of the gamma voltage unit 300, compared with the pixel structure 140nj' shown in FIG. 3. As such, by extending the available voltage range of the gamma voltage unit 300, it is possible to reduce influences by switching errors of the eleventh transistor M11j, the first transistor M1nj, etc.

[0166] As described above, in data driving circuits, data driving methods and light emitting displays employing one or more aspects of the invention, because a voltage of a data signal is reset using a compensation voltage generated when current sinks from a respective pixel, uniform images can be displayed regardless of electron mobility, threshold voltages, etc. of transistors.

[0167] Exemplary embodiments of the present invention have been disclosed herein, and although specific terms are employed, they are used and are to be interpreted in a generic and descriptive sense only and not for purpose of limitation. Accordingly, it will be understood by those of ordinary skill in the art that various changes in form and details may be made without departing from the spirit and scope of the present invention as set forth in the following claims.

What is claimed is:

1. A data driving circuit for driving a pixel of a light emitting display based on externally supplied first data for the pixel, wherein the pixel is electrically connectable to the driving circuit via a data line, the data driving circuit comprising:

- a gamma voltage unit generating a plurality of gray scale voltages;
- a digital-analog converter selecting, as a data signal, one of the plurality of gray scale voltages using k bits of the first data, k being a natural number;
- a decoder generating p bits of second data using the k bits of the first data, p being a natural number;
- a current sink receiving a predetermined current from the pixel during a first partial period of a complete period for driving the pixel based on the selected gray scale voltage;
- a voltage controller controlling a voltage value of the data signal using the second data and a compensation voltage generated based on the predetermined current; and
- a switching unit supplying the data signal, with the controlled voltage value, to the pixel, the switching unit supplying the data signal during any partial period of the complete period elapsing after the first partial period of the complete period.

2. The data driving circuit as claimed in claim 1, wherein the decoder converts the first data into a binary weighted value to generate the second data.

3. The data driving circuit as claimed in claim 1, further comprising:

- a first transistor disposed between the digital-analog converter and the switching unit, the digital-analog converter being turned on during a predetermined time of the first partial period to transfer the data signal, with the controlled voltage value, to the switching unit; and
- a first buffer connected between the first transistor and the switching unit.

4. The data driving circuit as claimed in claim 3, wherein the gamma voltage unit comprises:

- a plurality of distribution resistors for generating the gray scale voltages and distributing a reference supply voltage and a first supply voltage; and
- a second buffer for supplying the first supply voltage to the voltage controller.

5. The data driving circuit as claimed in claim 4, wherein the voltage controller comprises:

- p capacitors, each of the p capacitors having a first terminal that is connected to an electrical path between the first transistor and the first buffer;

second transistors respectively connected between a second terminal of each of the p capacitors and the second buffer; and

third transistors respectively connected between the second terminal of each of the p capacitors and the current sink, the third transistors being of a conduction type different from a conduction type of the second transistors.

6. The data driving circuit as claimed in claim 5, wherein the decoder turns on the second transistors during the first partial period, and supplies the first supply voltage to the respective second terminals of the p capacitors.

7. The data driving circuit as claimed in claim 5, wherein capacitances of the p capacitors are set to binary weighted values.

8. The data driving circuit as claimed in claim 7, wherein the decoder turns on and off the third transistors based on a number of bits of the second data and during the second partial period, the decoder selectively controls a supply of the compensation voltage to the respective second terminals of the p capacitors.

9. The data driving circuit as claimed in claim 1, wherein the current sink comprises:

- a current source providing the predetermined current;
- a first transistor disposed between the data line connected to the pixel and the voltage controller, the first transistor being turned on during the first partial period;
- a second transistor disposed between the data line and the current source, the second transistor being turned on during the first partial period;
- a capacitor storing the compensation voltage; and
- a buffer disposed between the first transistor and the voltage controller, the buffer selectively transferring the compensation voltage to the voltage controller.

10. The data driving circuit as claimed in claim 9, wherein a current value of the predetermined current is equal to a current value of a minimum current flowing through the

pixel when the pixel emits light with maximum brightness, and maximum brightness corresponds to a brightness of the pixel when a highest one of the plurality of reset gray scale voltages is applied to the pixel.

11. The data driving circuit as claimed in claim 1, wherein the switching unit comprises at least one transistor which is turned on during the second partial period.

12. The data driving circuit as claimed in claim 11, wherein the switching unit comprises two transistors which are connected so as to form a transmission gate.

13. The data driving circuit as claimed in claim 1, comprising:

- a shift register unit including at least one shift register for sequentially generating a sampling pulse;
- a sampling latch unit including at least one sampling latch for receiving the first data in response to the sampling pulse; and
- a holding latch unit including at least one holding latch for receiving the first data stored in the sampling latch and supplying the first data stored in the holding latch to the digital-analog converter and the decoder.

14. The data driving circuit as claimed in claim 13, further comprising:

- a level shifter for selectively modifying a voltage level of the first data stored in the holding latch and supplying the first data to the digital-analog converter and the decoder.

15. A light emitting display receiving externally supplied first data, comprising:

- a pixel unit including a plurality of pixels connected to n scan lines, a plurality of data lines, and a plurality of emission control lines;
- a scan driver respectively and sequentially supplying, during each scan cycle, n scan signals to the n scan lines, and for sequentially supplying emission control signals to the plurality of emission control lines; and
- a data driver receiving a predetermined current from respective ones of the pixels selected by a first scan signal during a first partial period of a complete period, respectively controlling voltage values of data signals using respective compensation voltages generated based on the respective predetermined current and respective second data generated by converting the respective first data into second data using binary weighted values, and respectively supplying the data signals, with the controlled voltage values, to the data lines during a partial period of the complete period that elapses after the first partial period of the respective complete period associated with each of the respective pixels.

16. The light emitting display as claimed in claim 15, wherein each of the pixels is connected to two of the n scan lines, and during each of the scan cycles, a first of the two scan lines receiving a respective one of the n scan signals before a second of the two scan lines receives a respective one of the n scan signals, and each of the pixels comprises:

- a first power source;
- a light emitter receiving current from the first power source;

first and second transistors each having a first electrode connected to the respective one of the data lines associated with the pixel, the first and second transistors being turned on when the first of the two scan signals is supplied;

a third transistor having a first electrode connected to a reference power source and a second electrode connected to a second electrode of the first transistor, the third transistor being turned on when the first of the two scans signal is supplied;

a fourth transistor controlling an amount of current supplied to the light emitter, a first terminal of the fourth transistor being connected to the first power source; and

a fifth transistor having a first electrode connected to a gate electrode of the fourth transistor and a second electrode connected to a second electrode of the fourth transistor, the fifth transistor being turned on when the first of the two scan signals is supplied such that the fourth transistor operates as a diode.

17. The light emitting display as claimed in claim 16, wherein each of the pixels comprises:

a first capacitor having a first electrode connected to one of a second electrode of the first transistor or the gate electrode of the fourth transistor and a second electrode connected to the first power source; and

a second capacitor having a first electrode connected to the second electrode of the first transistor and a second electrode connected to the gate electrode of the fourth transistor.

18. The light emitting display as claimed in claim 16, wherein each of the pixels further comprises a sixth transistor having a first terminal connected to the second electrode of the fourth transistor and a second terminal connected to the light emitter, the sixth transistor being turned off when the respective emission control signal is supplied,

wherein the current sink receives the predetermined current from the pixel during a first partial period of one complete period for driving the pixel, the first partial period occurring before a second partial period of the complete period for driving the pixel, and the sixth transistor is turned on during the second partial period of the complete period for driving the pixel.

19. A method for driving a light emitting display, comprising:

selecting, as a data signal, one of a plurality of gray scale voltages based on k bits of externally supplied first data, k being a natural number;

converting the first data into a binary weighted value and generating p bits of second data, p being a natural number;

receiving predetermined current from a pixel selected by a scan signal during a first partial period of a complete period for driving the pixel based on the selected gray scale voltage;

controlling a voltage value of the data signal using the generated second data and a compensation voltage generated when the predetermined current is supplied; and

after controlling the voltage value of the data signal, supplying the data signal to the pixel, the data signal being supplied to the pixel during a second partial period of the complete period for driving the pixel.

20. The method as claimed in claim 19, further comprising generating the plurality of gray scale voltages by distributing a voltage between reference supply voltage and a first supply voltage among a plurality of voltage dividing resistors.

21. The method as claimed in claim 19, wherein controlling the voltage value of the data signal comprises:

supplying a voltage value of the first power source to a first terminal of a each of a plurality of capacitors during the first; and

selectively controlling a supply of the compensation voltage to the respective second terminals of the plurality of capacitors based on a number of bits of the second data, during a second partial period of the complete period.

22. A data driving circuit for driving a light emitting display, comprising:

selecting means for selecting, as a data signal, one of a plurality of gray scale voltages based on k bits of externally supplied first data, k being a natural number;

converting means for converting the first data into a binary weighted value and generating p bits of second data, p being a natural number;

receiving means for receiving predetermined current from a pixel selected by a scan signal during a first partial period of a complete period for driving the pixel based on the selected gray scale voltage;

controlling means for controlling a voltage value of the data signal using the generated second data and a compensation voltage generated when the predetermined current is supplied; and

after controlling the voltage value of the data signal, supplying the data signal to the pixel, the data signal being supplied to the pixel during a second partial period of the complete period for driving the pixel.

* * * * *

专利名称(译)	数据驱动电路和使用其的有机发光显示器的驱动方法		
公开(公告)号	US20070024542A1	公开(公告)日	2007-02-01
申请号	US11/491880	申请日	2006-07-25
[标]申请(专利权)人(译)	众博ŷ RYU做H的 金弘꺀 KWON OH꺀		
申请(专利权)人(译)	众博ŷ RYU做H的 金弘꺀 KWON OH꺀		
当前申请(专利权)人(译)	三星DISPLAY CO. , LTD. IUCF-HYU		
[标]发明人	CHUNG BO YONG RYU DO HYUNG KIM HONG KWON KWON OH KYONG		
发明人	CHUNG, BO YONG RYU, DO HYUNG KIM, HONG KWON KWON, OH KYONG		
IPC分类号	G09G3/30		
CPC分类号	G09G3/2011 G09G3/3233 G09G3/3283 G09G3/3291 G09G2300/0819 G09G2320/043 G09G2300/0861 G09G2310/0251 G09G2310/027 G09G2310/0289 G09G2320/0276 G09G2300/0852		
优先权	1020050070438 2005-08-01 KR		
其他公开文献	US7893897		
外部链接	Espacenet USPTO		

摘要(译)

用于驱动发光显示器的像素以显示具有均匀亮度的图像的数据驱动电路可包括产生多个灰度电压的伽马电压单元，数字 - 模拟转换器，其选择多个中的一个作为数据信号使用第一数据的灰度级电压，使用第一数据产生第二数据的解码器，电流吸收器，使用第二数据控制数据信号的电压值的电压控制器和基于预定电流产生的补偿电压，以及在第一部分时段之后流逝的完整时段中的任何部分时段期间将数据信号提供给像素的切换单元。电流吸收器在用于基于所选择的灰度级电压驱动像素的完整时段的第一部分时段期间从像素接收预定电流。

